

**ROTATOR – PR60/100DM & IR60
OPERATION & MAINTENANCE MANUAL**

Ref: MNL-3426-03-0

LIMITED WARRANTY

ROMAR POSITIONING EQUIPMENT PTE LTD, Singapore, warrants all new equipment to be free from defects in material and workmanship for the period of one year, provided that the equipment is installed and operated according to instructions. Any repairs made by unauthorised third parties or modification without written consent shall void this warranty.

ROMAR POSITIONING EQUIPMENT PTE LTD's obligation, under this warranty, is expressed limited to replacing or repairing any defective part or correcting any manufacturing defect without charge during the warranty period, if **ROMAR's** factory inspection confirms the existence of such defects. **ROMAR's** option of repair or replacement will be at **ROMAR's** factory, 18 Tuas Crescent, Singapore, and therefore, no compensation for transportation cost of any kind will be allowed.

ROMAR POSITIONING EQUIPMENT PTE LTD will not be liable for any loss or consequential damage or expense accruing directly or indirectly from the use of equipment covered by this warranty.

Equipment manufactured by others but supplied by **ROMAR** shall carry the original makers warranty and shall be passed on to the buyer.

This warranty supersedes all previous **ROMAR** warranties and is exclusive with no other guarantees or warranties expressed or implied.

ROMAR POSITIONING EQUIPMENT PTE LTD
18 TUAS CRESCENT,
SINGAPORE 638712.

TEL : (65) 68610928/9

FAX : (65) 68613363

WEBSITE: <http://www.romar.com.sg>

EMAIL: sales@romar.com.sg

- The information contained in this manual is intended to be accurate. However the manufacturer retain the rights to make changes in design, which may not be included herein.



ROTATOR MODEL NUMBER FORMAT

1	2	3	4	5	6	7	8	9	10	11	12
---	---	---	---	---	---	---	---	---	----	----	----

1. MODEL

- IR - Conventional Idler
- PR - Conventional Power
- ISR - Self-Aligning Idler
- PSR - Self-Aligning Power

2. DRUM/TIRE

- [Blank] - Polyurethane
- R - Rubber
- S - Steel

3. LOAD CAPACITY PER PAIR

- 1.5 - 1.5 MT
- 5 - 5 MT
- 7 - 7 MT
- 15 - 15 MT
- 30 - 30 MT
- 60 - 60 MT
- 100 - 100 MT
- 120 - 120 MT
- [0~999] - Custom

4. TURNING CAPACITY

- [Blank] - N.A.
- /7 - 7 MT
- /10 - 10 MT
- /25 - 25 MT
- /45 - 45 MT
- /100 - 100 MT
- /150 - 150 MT
- /250 - 250 MT
- [/0~999] - Custom

5a. DRIVE

- [Blank] - N.A.
- SD - Single
- DM - Double
- TB - Torque Bar

5b. DRIVE MODULE ONLY

- [Blank] - N.A.
- SDP - Single Drive - Primary (Drive)
- SDS - Single Drive - Secondary (Idler)
- DMP - Double Drive - Primary (Drive)
- DMS - Double Drive - Secondary (Drive)
- TBP - Torque Bar Drive - Primary (Drive)
- TBS - Torque Bar Drive - Secondary (Driven)

6. ADDITIONAL FEATURE

- [Blank] - N.A.
- C - Counter Balance Arm Manual
- CM - Counter Balance Arm Motorised
- AC - Anti-Creep Device Manual
- ACM - Anti-Creep Device Motorised
- Y - Leadscrew Type C-C Adjustment

7. TRAVELCAR

- [Blank] - N.A.
- TC - Manual
- TCM - Motorised

8. ELECTRICAL

- [Blank] - N.A.
- XA - No panel, AC motor only
- XD - No panel, DC motor only
- EA - Panel 3-Phase & AC motor
- EB - Panel 1-Phase & AC motor
- EC - Panel 3-Phase & DC motor
- ED - Panel 1-Phase & DC motor
- FA - Panel 3-Phase, Foot Switch & AC motor
- FB - Panel 1-Phase, Foot Switch & AC motor
- FC - Panel 3-Phase, Foot Switch & DC motor
- FD - Panel 1-Phase, Foot Switch & DC motor
- SA - Panel 3-Phase, Synchronize & AC motor
- SB - Panel 1-Phase, Synchronize & AC motor
- SC - Panel 3-Phase, Synchronize & DC motor
- SD - Panel 1-Phase, Synchronize & DC motor

9. MAX. ROLLER C-C

- [Blank] - N.A.
- 2300 - 2300mm
- 2700 - 2700mm
- 3100 - 3100mm
- [-0~9999] - Custom

10. TRACK GAUGE TYPE

- [Blank] - N.A.
- /C - C-C
- /G - G-G

11. TRAVELCAR TRACK GAUGE

- [Blank] - N.A.
- 1435 - 1435mm
- 1650 - 1650mm
- 1950 - 1950mm
- [0~9999] - Custom

12. SPECIAL

- [Blank] - N.A.
- Z - Custom



IDENTIFICATION DATA

Purchaser : A&N Plant & Equipment
End User : Romar Positioning USA
Order Number : AM00609 (JV-USA)

Romar Order : 3426 J
Equipment Type : Rotator
Model : (1) PR60/100DM-XP-3100
(2) IR60-3100
Serial Number : (1) 3426-03A, 3426-03B, 3426-03C,
3426-03D & 3426-03E
(2) 3426-04A, 3426-04B & 3426-04C,
3426-04D & 3426-04E
Loading Capacity : (1) 30 metric tons
(2) 30 metric tons
Rotating Capacity : (1) 100 metric tons
Vessel Size (min) : Dia 466mm at 90 degree Included Angle
Vessel Size (max) : Dia 11457 mm at 30 degree Included Angle
Rotating Speed : 130 ~ 1295 mm/min 2 x 1.5 kW (at 5-50 Hz)
Voltages : N.A.
Control : N.A.
Synchronisation : N.A.
Net Weight : (1) 2060 Kg
(2) 1295 Kg
Quantity : (1) 5 units
(2) 5 units

Please quote the above details when ordering spares or in any other communications regarding this equipment.

CONTENT PAGE

	No. Of Pages
1. Preface	2
2. Operating & Maintenance Manual	9
3. Appendix A – Mechanical Drawing	5
4. Appendix B – Drive Motor -Model: WAF 91L4 FL	28
5. Appendix C – Gearbox -Model :RHX-155-600	2
6. Appendix D – Suitable Vessel Diameter	1

PREFACE

1. General Safety Instruction

- 1.1 This manual must be thoroughly understood prior to actual installation and operating the machine.
- 1.2 In additional to the manual, please consult other manuals of associated equipment such as Overhead crane.
- 1.3 Please observe applicable legal and other mandatory regulations relevant to accident prevention and environment protection. These compulsory regulations may also deal with handling of hazardous substances, issuing and/or warning of personal protective equipment, or traffic regulations.
- 1.4 Installation instruction contained herein must be supplemented by instructions covering all duties involved in supervising and notifying other parties working within the area of operation.
- 1.5 Observe all basic safety rules using the correct tools and lifting slings, wearing of PPE etc.
DO NOT COMPROMISE ON SAFETY.
- 1.6 Always use Lifting Lugs provided on the Equipment.

2. Installation Preparation

- 2.1 During design and installation it is vital to take into account relevant standards and regulation, the load bearing capacity of building or floor or other attachment devices.
- 2.2 Before starting installation, prepare a sketch or drawing showing the extent of the ROMAR Rotator System and its required area of operation with respect to building.
- 2.3 Use only origin ROMAR components. When using supplementary bolt etc use only the specified grade.
- 2.4 ROMAR Rotator is designed for ready-to-use and there is no further Mechanical Installation Requirement except to provide connection to the Electrical Supply. However, we recommended that a thorough Visual Inspection to be carried out to ascertain that no visual damage has occurred during the course of shipment and transit.
- 2.5 We recommend that, after completion of installation but before taking the unit into service, it is commissioned by recognized expert in the field. We remain naturally at your service with hints and advise should you require them. It better to ask once too much – nothing must be unclear. We trust that with proper installation procedure, your ROMAR Rotator will provide you years of trouble free service.

1. GENERAL

1.1 ROMAR Turning Rolls or Rotators are robustly built and use Diameter 520mm Polyurethane tyres for durability and superior traction. It is designated to withstand the rugged and harsh environment expected of such application. Detail attentions such as grit blasting to SA 2.5 for all Structural Steel Work and Polyurethane paintwork will ensure that our Equipment provides you with many years of uninterrupted use.

1.2 ROMAR Rotators are supplied as Powered Rolls and Idler Rolls (unpowered).

1.3 Main Component

1.3.1 Table (1) Powered Rolls (per set)

Item Number	Description	Quantity	Remarks
1	Skid	1	C-C :700-3100
2	Tyres Module	2	
3	Primary Gearbox	2	
4	Secondary Gearbox	2	
5	Drive motor	2	

1.3.1 Table (2) Powered Rolls (per set)

Item Number	Description	Quantity	Remarks
1	Skid	1	C-C :700-3100
2	Tyres Module	2	

2. Main Specification

2.1 Powered Roll

- 2.1.1 Model : PR60/100DM-XP-3100
- 2.1.2 Loading Capacity : 30 metric tons
- 2.1.3 Rotation Capacity : 100 metric tons
- 2.1.4 Vessel Size (min) : 466 mm at 90 degree Included Angle
- 2.1.5 Vessel Size (max) : 11457 mm at 30 degree Included Angle
- 2.1.6 Rotation Speed : 130-1295 mm/min 2 x 1.5kW (at 5-50 Hz)
- 2.1.7 Incoming Supply : N.A.
- 2.1.8 Control Voltage : N.A.
- 2.1.9 Synchronisation : N.A.
- 2.1.10 Control Means : N.A.
- 2.1.11 Surface Preparation: Grit Blast to SA 2.5
- 2.1.12 Painting : 2 coat zinc phosphate + 1 coat polyurethane
- 2.1.13 Colour : RAL5015 Blue
- 2.1.14 Tyre Size : Dia 520x178mm (PU), 2 Tyres per Drum
- 2.1.15 Weight, Net : 2060 kg

2.2 Idler Roll

- 2.2.1 Model : IR60-3100
- 2.2.2 Loading Capacity : 30 metric tons
- 2.2.3 Vessel Size (min) : 466 mm at 90 degree Included Angle
- 2.2.4 Vessel Size (max) : 11457 mm at 30 degree Included Angle
- 2.2.5 Surface Preparation: Grit Blast to SA 2.5
- 2.2.6 Painting : 2 coat zinc phosphate + 1 coat polyurethane
- 2.2.7 Colour : RAL5015 Blue
- 2.2.8 Tyre Size : Dia 520x178mm (PU), 2 Tyres per Drum
- 2.2.9 Weight, Net : 1295 kg

3. Basic Construction

3.1 Skid

- 3.1.1 The skid is constructed from channel, welded together and drilled precisely to accommodate the different centre to centre of **Roller Frame**.
- 3.1.2 It must be used on a designated place where the floor is level and able to sustain the loading from work piece.

3.2 Tyres module

- 3.2.1 This Tyres module consists a Cast-Steel Drum whereby the Polyurethane tyres (Individual size: 520 mm x 178 mm (w)) are hydraulically pressed into it.
- 3.2.2 The **PU tyres** are protected from being overloaded via 2 pieces of **Overload Disc**.

3.3 Primary Gearbox

3.3.1 The Primary Gearbox is of worm design and is coupled to a AC Squirrel Cage motor via flange.

3.3.2 It is supplied fully aligned and no further adjustment is required.

3.4 Secondary Gearbox

3.4.1 The Secondary Gearbox is coupled to the Primary Gearbox via flange.

3.4.2 The output shaft is fitted with a high quality heat-treated pinion and meshed with the side gear of the Steel Drum. This provides the basis of rotation for the Roller.

3.4.3 Each Powered Roller is equipped with its own Primary/Secondary Gearbox cum motor. Both Powered Roller are symmetrical and seat on the same skid.

3.5 Drive Motor

3.5.1 This Drive Motor is a Squirrel cage A/C motor of IEC flange-mounted design.

3.5.2 It is flange-mounted directly to the Primary Gearbox.

3.5.3 Both motors are controlled via an Inverter and equipped with Forced-Cooled fan for excellent dissipation of heat during low revolution.

4. Installation

4.1 ROMAR rotators are design for immediate put-to-use.

4.2 No mechanical connection is required.

4.3 Select the area for Installation. This should be preferably level and able to take the load of work piece without subsequent soil settlement.

4.4 Study the area of operation to ensure that it will be large enough for the work piece where extension will be required.

4.5 Do not mix the Powered and Idler Rolls of different maker or types.
IT MUST SHARE THE SAME CENTRE DISTANCE.

- 4.6 Place both the Powered and Idler rolls in the best alignment possible. It is recommended to invest in this initial set-up process.
- 4.7 Do not anchor the skids to the floor if the ratio of work piece Diameter to Length is less than 1. This floating arrangement tends to "right" itself if there is misalignment from the set-up or from the work piece itself.
- 4.8 Anchor the skids to the floor if the ratio of work piece Diameter to Length is greater than 1. There is a greater chance of work piece falling over its Diameter's plane, thus causing the Rolls to tip over in the same plane.
- 4.9 The number of idler rolls should be increased if possible especially in big diameters or thinner wall thickness.
- 4.10 Connect the control panel (not included) and the 3-phase supply once the set-up is completed.
- 4.11 Test the forward/reverse function to ensure that the phases coincide with the equipment. See Fig 4-1.

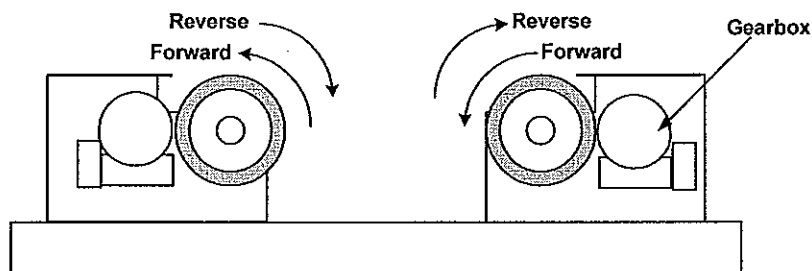

Fig 4-1

- 4.12 If the "forward" function operates the reverse rotation, change any 2 phases of the supply.
- 4.13 Trial run rotating motions in both direction and observes if there is any unusual noise or smell.

5. OPERATION INSTRUCTIONS & HINTS

5.1 The below-mentioned points are to be noted by the user when the turning rolls are being utilized.

5.1.1 Included Angle

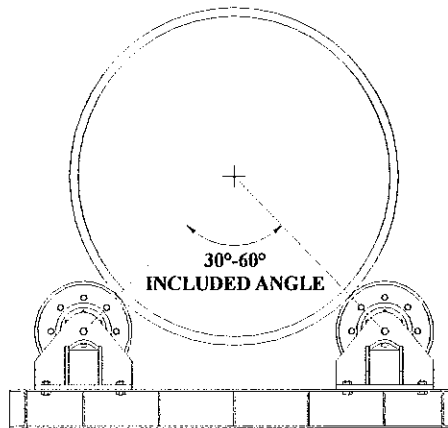

Under normal circumstances for general application, the Rotator centre distance of wheels apart, by standard industry practice, is of 30 degrees to 60 degrees included angle, for concentric balance loads. A pair of Rotators with the centre set apart at angle of 30 degrees will require less torque or tractive pull when compared with a similar pair set at angle of 45 degrees or 60 degrees. Increasing the included angle towards the upper end of the recommended range will increase the torque required to pull it. Concentric loads are usually set on small centre distance apart where as eccentric loads are usually set on wider centre distance apart.

Theoretically, small-included angles, down to even 20 degrees or 25 degrees can be utilized safely on heavy and rigid concentric loads. However, it is not the responsibility of the manufacturer but the user's, that is to check on the safety aspects of using such or any centre distance of rolls setting as each work piece vary in different "Dimension C-C" settings.

5.2 Work piece Analysis

5.2.1 Generally, the factors to be taken into considerations before setting up a job are as follows: -

- i. rigidity
- ii. roundness
- iii. weight
- iv. diameter
- v. C.G of the job

... And other prevailing conditions that will affect the rotation, protrusions of sagging due to too thin material/bigger diameters.

5.3 Roller Alignment

Roller alignment setting is very important because it will affect the job, longitudinally that is, from rolling and falling over the Rotators. Hence, the user needs to ensure that:

- i. The centreline of the powered and idler units must be parallel.
- ii. The floor has to be flat and level.

5.4 Height Over Width "Toppling"

It is always a good practice to ensure that the outside diameter of the job should not exceed its length when performing all the normal settings. And should the length be greater than its diameter, extra care must be taken when anchoring the Rotators to the floor. The user can also employ idler units to increase the stability of the job when in operation.

6 Start Operation

- 6.1 Before rotating any work piece, bring speed down potentiometer to minimum.
- 6.2 Start rotating work piece in desired direction, and increasing the speed gradually.
- 6.3 Always ensure that the work piece is in good contact with the Power and Idler units used.
- 6.4 When a Power unit is used with more than one Idler unit, the Power unit should always be located at one end of the vessel, so as to ensure contact with the load and prevent slipping.
- 6.5 In case roller slipping occur, it can usually be overcome by :
 - 6.5.1 Increase the units centre distance to increase traction.

- 6.5.2 Remove dirt and grease from the rolls surface and work piece surface.
- 6.5.3 Redistribute the load on the Power and Idler units in order to make greater proportion of the load lie on the Power units and hence, increase traction.
- 6.5.4 Cylindrical work piece tends to move along the longitudinal axis as it rotates. Having Rotators of the same centre can prevent this distance, height and diameter.
- 6.5.5 "Longitudinal Creep" is quite a problem but usually can be corrected by having the 2 sets i.e. Power Roll & Idler Roll level and squareness checked and shimmed to level and alignment with cross-checking (Diagonal) dimensionally.
- 6.5.6 In case of doubts of the machine **functionalities**, always report to supervisor and discontinue the use of equipment until it has been rectified / certified by Maintenance personnel.

7. MAINTENANCE OF MECHANICAL PARTS

- 7.1 Preventive maintenance consists of inspecting, adjusting and cleaning of the static and dynamic parts of the whole mechanical unit. Regular inspections at intervals dependent upon the service conditions are the best insurance against costly breakdown.
- 7.2 All moving parts, for example, bearings and couplings, are to be lubricated at regular intervals. Nipples are to be greased by means of a grease gun, so that the internal moving parts can be lubricated, hence, prolong the life-span of the whole mechanical unit.
- 7.3 Before running the machine at any time, the user must ensure that all the reducers and the transmission have oil up to the proper level in their respective cases. Oil of proper grade for local use must be regularly checked and top-up to commensurate with either time or usage, whichever is earlier.
- 7.4 Attempt must be made to eliminate all sources of contamination, moisture and for maximum insulation life for electrical motors. Periodic cleaning using compressed air is required.

8. Maintenance**Table (3) MAINTENANCE PLAN**

S/N	Component	Inspection & Action	Lubricant & Detergent Code	Duration of Operation	Quantity
1	Gear Train	Grease	Shell EP Grease 1128	As required.	As required.
2	Coupling	Check condition	Shell EP Grease 1128	2,000 Hrs	As required.
3	Primary Gearbox	Oil change	Omala Oil 220	As Necessary/ 2,000 Hrs or 18 Month	8.4L
4	Secondary Gearbox	Grease change	Shell Omala 18	As Necessary/ 2,000 Hrs or 18 Month	19L

Note : (1) Use white spirit to clean Gear Train during replacement of Grease.

(2) All grease nipple to be charged every 3 months.

APPENDIX A

**GENERAL ARRANGEMENT
DRAWINGS**

Specification for Rotator

1	Model	PR60/100DM-XP-3100
2	Capacity (Loading)	30 TON
3	Capacity (Turning)	100 TON
4	Vessel Size (Min.)	ø466mm at 90° Included Angle
5	Vessel Size (Max.)	ø11457mm at 30° Included Angle ø7580mm at 45° Included Angle ø5679mm at 60° Included Angle
6	Tyre and Size	Polyurethane, ø20.5" x 14"
7	Electrical Panel	Yes*
8	Roller Speed	156 to 1560mm/min at 6 to 60Hz
9	Incoming Supply	460V-3P-60Hz
10	Control Voltage	N.A.
11	Roller Drive Control	N.A.
12	Control Means	N.A.
13	Roller Drive Motor	2 x AC 1.5KW c/w Force Cooling
14	Travelcar (Boogie)	N.A.
15	Travelcar Speed	N.A.
16	Surface Preparation	Gritblast to SA2.5
17	Painting	2 coats Zinc Phosphate, 1 coat Polyurethane
18	Color	RAL 3003 Red
19	Qty	4 units
20	Weight	2080 Kg

*Note: Empty Enclosure c/w holes/glands, motor is wired (cable marked) with cabling to the panel.

4

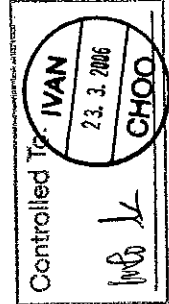
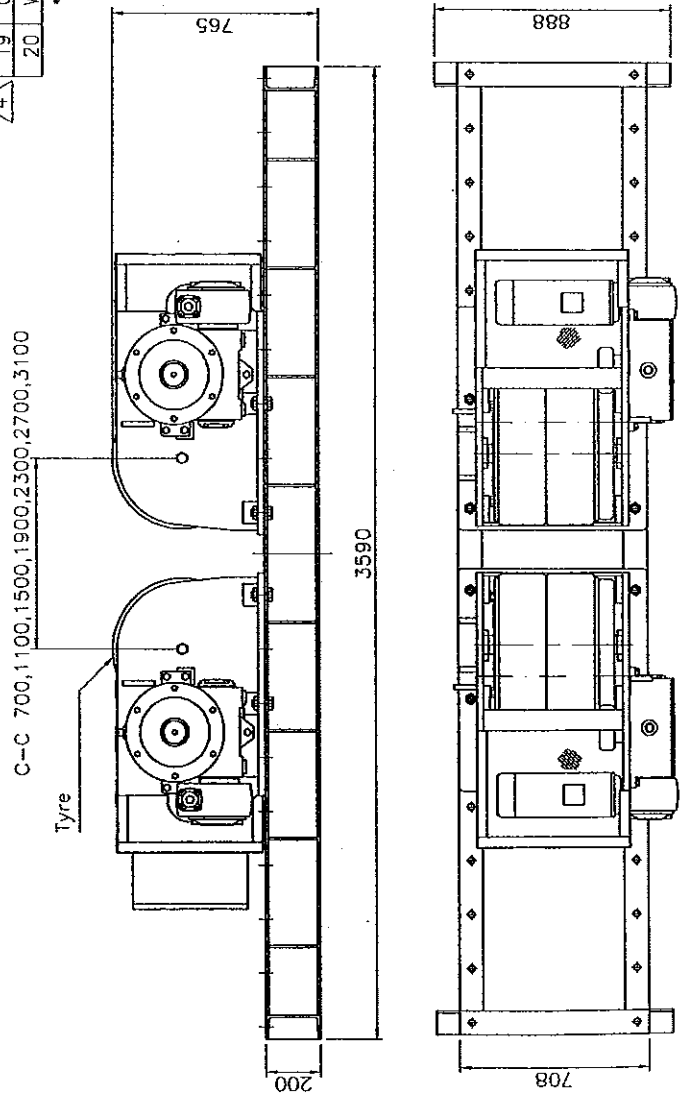

DRAWN		DATE		PROJECT/MODEL	
REVISED		23-02-08		PR60/100DM-XP-3100	
APPROVED		[Signature]		CLIENT: A&N Plant/Romar USA	
[Signature]		DWG. NAME: GENERAL ARRANGEMENT		SCALE: INT.S.	
[Signature]		DWG. NO.: PJ-3426-GA03		REVISION	
[Signature]		THE ORIGINAL AND ALL COPIES OF THIS DRAWING TOGETHER WITH THE COPYRIGHT THEREOF ARE THE SOLE PROPERTY OF R.P.E. PTE. LTD. SINGAPORE		SHEET NO. 1 OF 1	

ALL DIMENSIONS IN MM, UNLESS OTHERWISE SPECIFIED.

SIZE: A3

Specification for Rotator

1	Model	IR60-3100
2	Capacity (Loading)	30 metric tons
3	Capacity (Turning)	N.A.
4	Vessel Size (Min.)	ø466mm at 90° Included Angle
5	Vessel Size (Max.)	ø11457mm at 30° Included Angle ø7580mm at 45° Included Angle ø5679mm at 60° Included Angle
6	Tyre Type and Size	Polyurethane, ø20.5"x14"
7	Travelcar (Boat)	N.A.
8	Travelcar Speed	N.A.
9	Surface Preparation	Gritblast to SA2.5
10	Painting	2 coats Zinc Phosphate, 1 coat Polyurethane
11	Color	RAL 3003 Red
12	Qty	6 units
13	Weight	1290 Kg



C-C 700, 1100, 1500, 1900,
2300, 2700, 3100

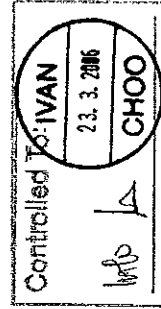
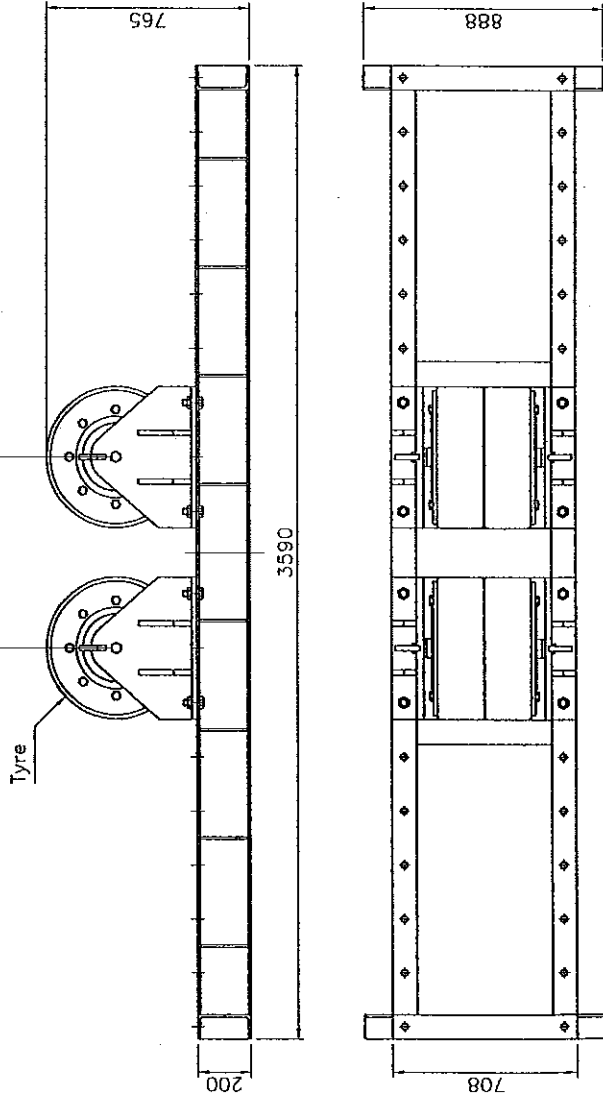

DRAWN		NAME	DATE
KPH		KPH	23-02-06
APPROVED		DWC. NAME : ROTATOR GENERAL ARRANGEMENT	
DWC. NO. :		PJ-3426-GA04	
SHEET NO. :		1 OF 1	
THE ORIGINAL AND ALL COPIES OF THIS DRAWING TOGETHER WITH THE COPYRIGHT THEREOF ARE THE SOLE PROPERTY OF R.P.E. PTE. LTD. SINGAPORE			
PROJECT/MODEL : IR60-3100			
CLIENT : A&N Plant/Romar USA			
SCALE : N.T.S.			
REVISION :			

ALL DIMENSIONS IN MM, UNLESS OTHERWISE SPECIFIED.

SIZE: A3

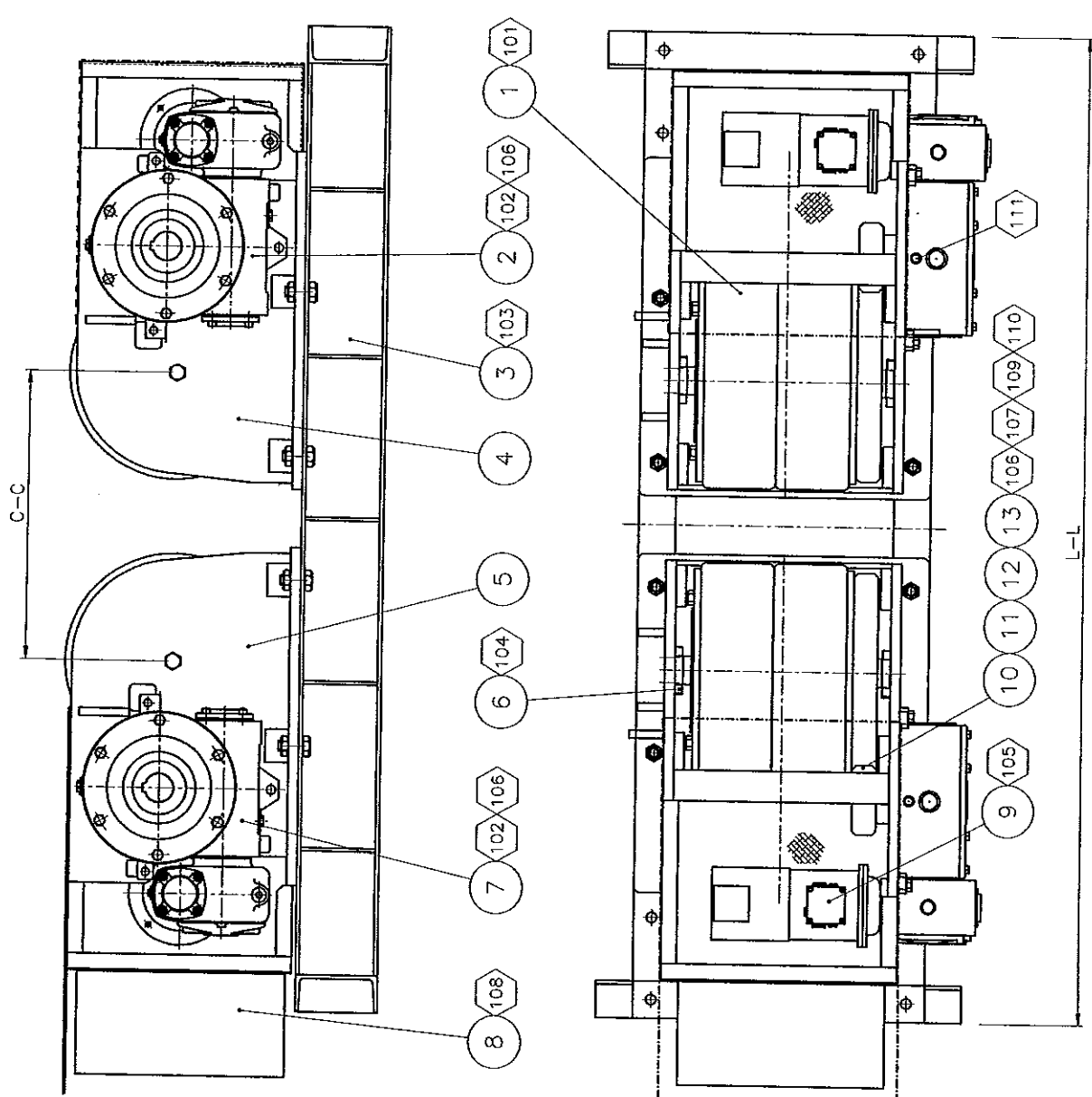

Note:
 1. All fasteners to be galvanised unless otherwise stated.
 2. All bolt ore to be grade 8.8 unless otherwise stated

NO	PART NUMBER	DESCRIPTION	QTY	REMARKS
111	-	M12X16 BUTION HEAD SCREW	2	Gearbox
110	-	KEY 13X20X78	2	
109	-	KEY 13X20X189	2	
108	-	M12X16 BUTION HEAD SCREW	4	Electical Panel
107	-	M12X16 SOCKET SET SCREW	4	Phren Gear
106	-	M12X35 CAP SCREW	4	Washer
105	-	M10X30 B/SW	8	Motor
104	-	M14X50 B/SW	4	Lock Plate
103	-	1/2X2X7.5 B/N/SW/TW	8	SKd
102	-	M16X50 B/SW	6	Gearbox
101	-	M24X60 B/SW	4	Tin Shaft
13	SD-R060-M005	PNOM SHAFT	2	
12	SD-R000-M003	WASHER B	2	
11	SD-R000-M002	WASHER A	2	
10	SD-R000-M005	PNOM GEAR	2	99-R060M00045
9	-	MOTOR AC 1.5KW	2	WAFB114-F1
8	-	ELECTRICAL PANEL	1	
7	SD-R002-0240	Gear RFE-RFK-155-600-2-F-EC	1	
6	SD-R000-M006	LOCK PLATE	2	
5	SD-R060-S003	LEFT FRAME ASSEMBLY BOT POWER	1	
4	SD-R060-S002	RIGHT FRAME ASSEMBLY BOT POWER	1	
3	SD-R060-Z010	SKD 50T	1	
2	SD-R002-2030	Gear RFE-RFK-155-600-2-E-EC	1	
1	SD-R060-S001	TRE MODULE ASST - BOT POWER	2	

ROMAR POSITIONING EQUIPMENT PTE LTD
<http://www.romar.com.sg>

PROJECT/MODEL : PR60/100 DM

CLIENT : -

DWG. NAME : GENERAL ASSEMBLY

DWG. NO. : SD-R060-A001

SCALE : 1:1

REV. NO. : 0

SHEET NO. : 1 OF 1

DATE : 17-08-03

APPROVED : *[Signature]*

THE ORIGINAL AND ALL COPIES OF THIS DRAWING TOGETHER WITH THE COPYRIGHT THEREOF ARE THE SOLE PROPERTY OF R.P.E. PTE. LTD. SINGAPORE.

SIZE: A3

Controlled To: FRANKIE
 17.08.03
 G011

ALL DIMENSIONS IN MM, UNLESS OTHERWISE SPECIFIED.

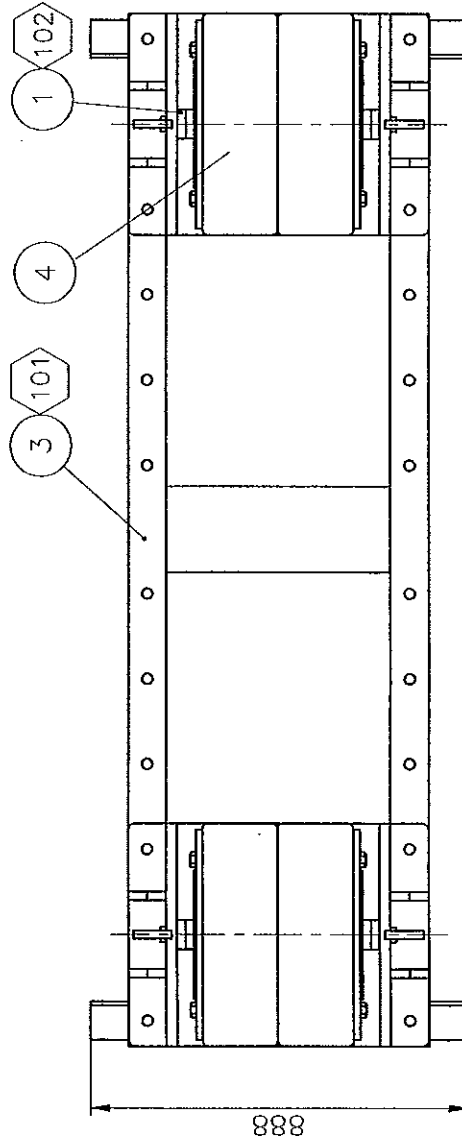
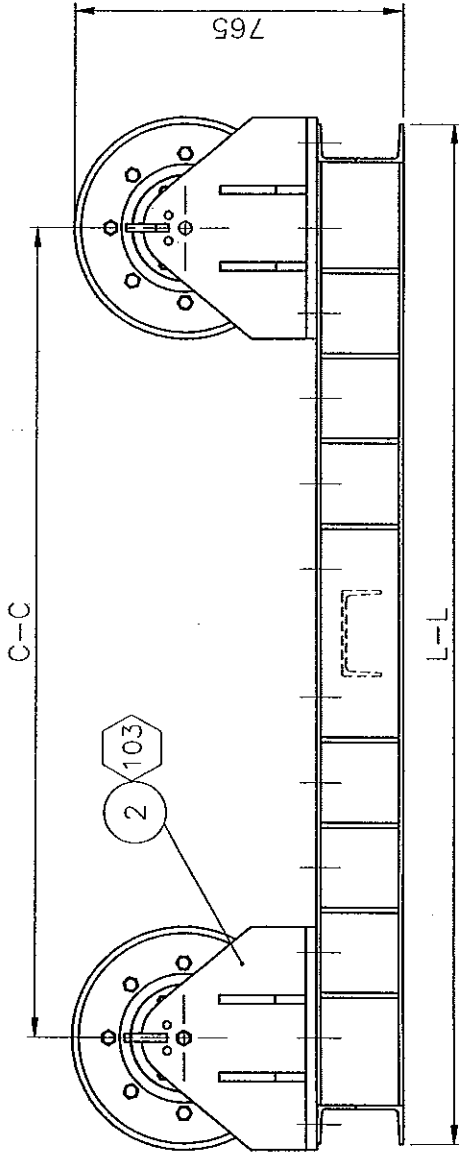

Note:
 1. All fasteners to be galvanised unless otherwise stated.
 2. All bolt are to be grade 8.8 unless otherwise stated

NO	PART NUMBER	DESCRIPTION	QTY	REMARKS
103	-	M24x60 B/SW	4	
102	-	M14x50 B/SW	4	
101	-	M22x75L B/N/SW/TW	8	
4	SD-R060-S005	TIRE MODULE ASSEMBLY - 60T Idler	2	
3	SD-R060-Z010	SKID 60T	1	
2	SD-R060-S004	IDLER FRAME ASSEMBLY	2	
1	SD-RXXX-M006	LOCK PLATE	2	

 ROMAR POSITIONING EQUIPMENT PTE LTD http://www.romar.com.sg		PROJECT/MODEL : IR60	
DRAWN : APPROVED :	NAME : CPTAN	DATE : 15-09-03	CLIENT : - DWG. NAME : GENERAL ASSEMBLY DWG. NO. : SD-R060-A601
SCALE: 1 : 1B REVISION: 0 SHEET NO: 1 OF 1		THE ORIGINAL AND ALL COPIES OF THIS DRAWING TOGETHER WITH THE COPYRIGHT THEREOF ARE THE SOLE PROPERTY OF R.P.E. PTE. LTD. SINGAPORE	

Controlled To File
 30.10.11
 FRANKIE
 MOSEY
 GOF

ALL DIMENSIONS IN MM, UNLESS OTHERWISE SPECIFIED.

SIZE: A4

APPENDIX B

DRIVE MOTORS Model: WAF 91L4 FL

Watt Drive Antriebstechnik GmbH

Ein Unternehmen der Wustinger-Gruppe

A-2753 Markt Piesting, Wöllersdorferstraße 68

Tel.: +43/2633/404-0, Fax: +43/2633/404-220

www.wattdrive.com

watt@wattdrive.com

Description of Product

Type of motor :

Motor

Type :

WAF91L4-FL

Motor Data :

Motor Power :	1,5	[kW]
Nominal Speed :	1420	[1/min]
Rated torque :	10,1	[Nm]
Voltage :	220-240/380-420	[V]
Frequency :	50	[Hz]
Connection :	D/Y	
Rated current :	6,0/3,45	[A]
Starting to rated current :	6,3	
cos ϕ :	0,82	
Protection class :	IP 55 - Protection against harm ful dust deposits and water jets	
Mounting position :	B5	
Position of the terminal box :	A	
Insulation class :	F	
Output flange :	Ø200 according to IEC	
Output Shaft :	Ø 24 k6 x 50	[mm]
Keyway :	DIN 6885.1	
Painting :	Standardpainting 80-100µm	
Color :	RAL 5023 (Distant blue)	

Options :

Fan :	Forced cooling 1x230V +/-10% IP55 50/60Hz
Position of T/Box for the forced cooling :	At the terminal box

Watt Drive Antriebstechnik GmbH

Ein Unternehmen der Wustinger-Gruppe

A-2753 Markt Piesting, Wöllersdorferstraße 68

Tel.: +43/2633/404-0, Fax: +43/2633/404-220

www.wattdrive.com

watt@wattdrive.com

Description of Product

Type of motor :

Motor

Type :

WAF91L4-FL

Motor Data :

Motor Power :	1,5	[kW]
Nominal Speed :	1725	[1/min]
Rated torque :	8,3	[Nm]
Voltage :	220-280/380-480	[V]
Frequency :	60	[Hz]
Connection :	D/Y	
Rated current :	5,91/3,41	[A]
Starting to rated current :	7,1	
cos φ :	0,83	
Protection class :	IP 55 - Protection against harm ful dust deposits and water jets	
Mounting position :	B5	
Position of the terminal box :	A	
Insulation class :	F	
Output flange :	Ø200 according to IEC	
Output Shaft :	Ø 24 k6 x 50	[mm]
Keyway :	DIN 6885.1	
Painting :	Standardpainting 80-100µm	
Color :	RAL 5023 (Distant blue)	

Options :

Fan :	Forced cooling 1x230V +6/-10% IP55 50/60Hz
Position of T/Box for the forced cooling :	At the terminal box

Watt Drive Antriebstechnik GmbH

Ein Unternehmen der Wustinger-Gruppe

A-2753 Markt Piesting, Wöllersdorferstraße 68

Tel.: +43/2633/404-0, Fax: +43/2633/404-220

www.wattdrive.com

watt@wattdrive.com

Description of Product

Type of motor :

Motor

Type :

WAF91L4-FL

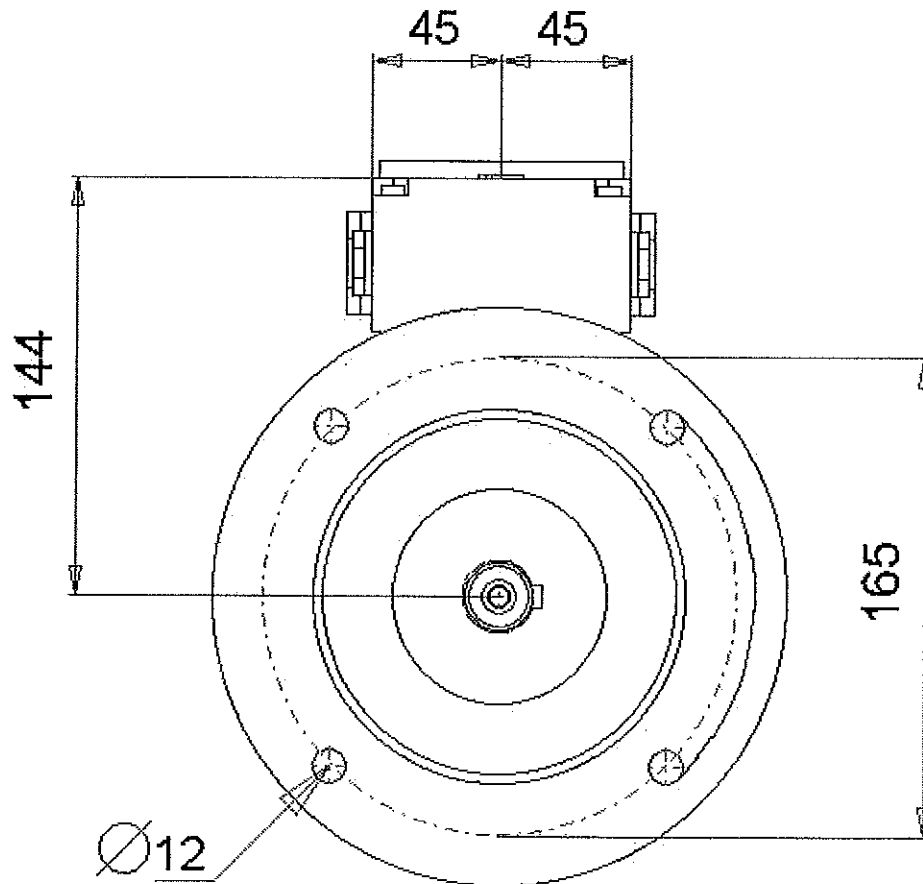

Watt Drive Antriebstechnik GmbH

Ein Unternehmen der Wustinger-Gruppe

A-2753 Markt Piesting, Wöllersdorferstraße 68

Tel.: +43/2633/404-0, Fax: +43/2633/404-220

www.wattdrive.com

watt@wattdrive.com

Description of Product

Type of motor :

Motor

Type :

WAF91L4-FL

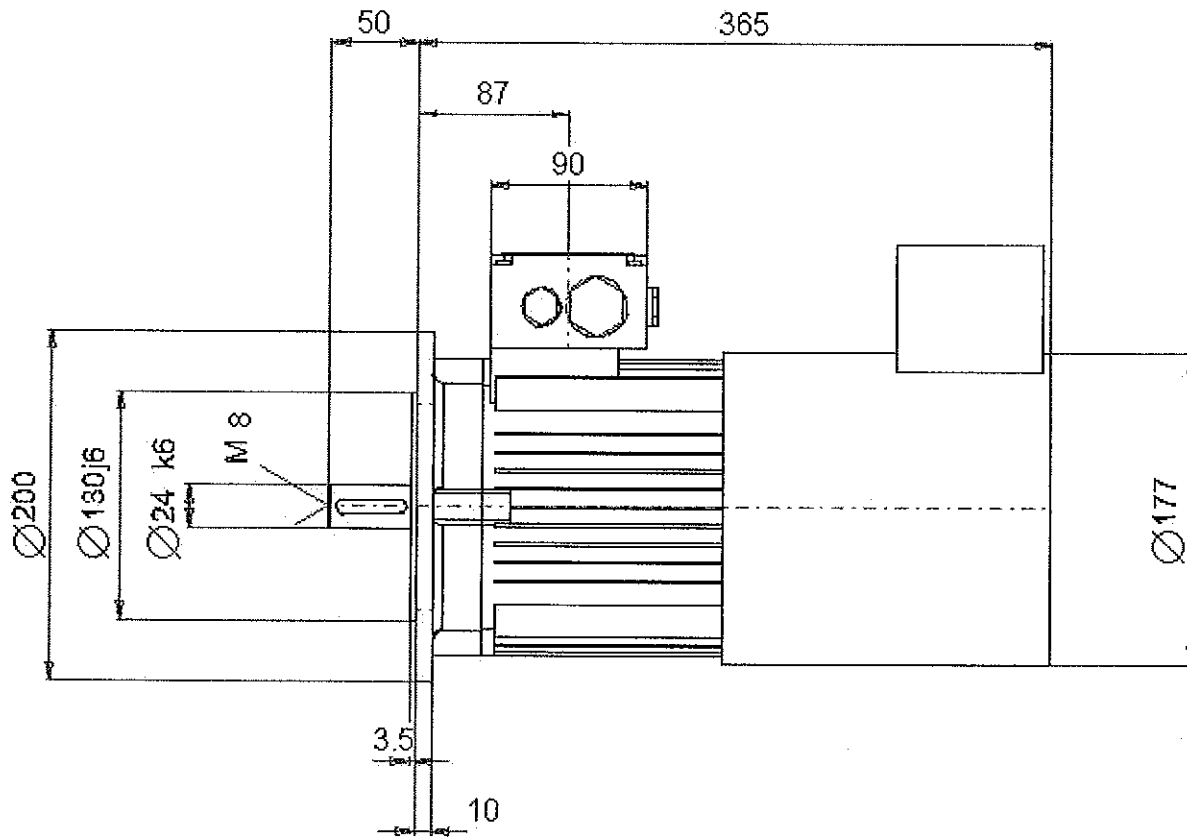

Betriebs- und Wartungsanleitung

Operating and maintenance manual

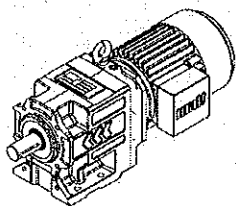

**MAS 2000 -
Stirnradtriebmotoren**
Helical geared motors

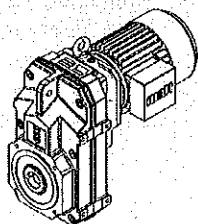

**MAS 2000 -
Aufstecktriebmotoren**
Shaft mounted geared motors

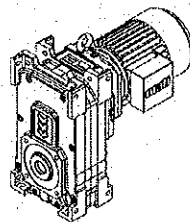

**MAS 2000 -
Flachtriebmotoren**
Parallel shaft geared motors

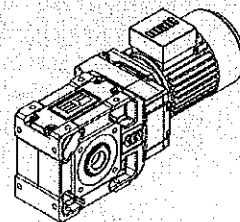

**MAS 2000 -
Kegelstirnradtriebmotoren**
Helical bevel geared motors

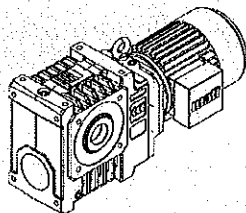

**MAS 2000 -
Stirnradschneckentriebmotoren**
Helical worm geared motors

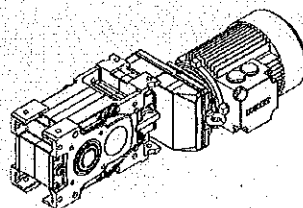

**MAS 2000 -
Kegelflachtriebmotoren**
Angle parallel shaft geared motors

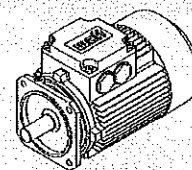

EUSAS-Motor WAR
EUSAS-motor WAR

MAS 2000 - Getriebe und Getriebemotoren

MAS 2000 - Gear units and geared motors

Inhaltsverzeichnis	Seite	Contents	page
1. Sicherheitshinweise	1	1. Safety Instructions	1
2. Allgemeines	2	2. General	2
3. Einbau	2	3. Installation	2
4. Elektrischer Anschluß	3	4. Electrical connection	3
5. Montage von Übertragungselementen	5	5. Mounting transmission devices	5
6. Schmierung und Wartung	5,6	6. Lubrication and maintenance	5,6
6.1.1. Stirnradgetriebe	7	6.1.1. Helical gear unit	7
6.1.2. Einstufige Stirnradgetriebe	8	6.1.2. Single stage helical gear units	8
6.1.3. Aufsteckgetriebe	9	6.1.3. Shaft mounted gear units	9
6.1.4. Flachgetriebe	10	6.1.4. Parallel shaft gear units	10
6.1.5. Kegelstirnradgetriebe	11	6.1.5. Helical bevel gear unit	11
6.1.6. Kegelflachgetriebe	12	6.1.6. Angle parallel shaft gear unit	12
6.2.1. Stirnrad-schneckengetriebe	13	6.2.1. Helical worm gear units	13
7. Montage und Demontage eines Getriebes mit Hohlwelle	6	7. Assembling and dismantling a gear unit with hollow shaft	6
8. Schmierstoffempfehlung	14	8. Recommended lubricants	14
9. Schaltungsschema für Drehstrommotoren	15,16	9. Three phase motors connection diagram	15,16
10. Technische Beschreibung - Bremse	17	10. Technical specifications - brake	17
11. Gleichrichter	18,19	11. Rectifier	18,19
12. Montage und Dem. von Schrumpfscheiben	20	12. Installation and removal of shrink disks	20

1. Sicherheitshinweise

- Der Kunde ist verantwortlich für die fachgerechte Aufstellung des Antriebes.
Bestätigte Eigenschaften der Antriebe sowie die Erfüllung eventueller Garantieansprüche bedingen die Einhaltung der Hinweise in dieser Betriebsanleitung.
- Achten Sie darauf, niemals beschädigte Produkte in Betrieb zu nehmen!
- Lesen Sie die Betriebsanleitung sorgfältig, bevor Sie mit Aufstell-, Montage- oder Wartungsarbeiten beginnen.
- Beachten Sie unbedingt die in der Betriebsanleitung enthaltenen Sicherheitshinweise, die wie folgt gekennzeichnet sind:

1. Safety Instructions

- The user is responsible for correct installation of the drive unit. Drive unit properties can only be guaranteed and warranty claims considered if the instructions in this manual have been observed.
- Never use damaged products.
- Please read the operating instructions carefully before starting any installation, assembly or maintenance work.
- Follow the safety instructions in the manual at all times. For easy identification they are marked as follows:

	Warnung vor elektrischer Gefahr, z.B. Bei Arbeiten unter Spannung. Warning of electrical danger, e.g. working with live machines.
	Warnung vor mechanischer Gefahr, z.B. Arbeiten an Hubwerken. Warning of mechanical danger, e.g. working with hoisting equipment.
	Wichtige Anweisung für sicheren und störungsfreien Betrieb. Important instructions for safe, trouble-free operation.

- Warnung:**
Spannungsführende und bewegte Teile in elektrischen Maschinen können schwere oder tödliche Verletzungen verursachen.
Montage, Anschluß, Inbetriebnahme, sowie Wartungs- und Reparaturarbeiten dürfen nur durch **qualifiziertes Fachpersonal** erfolgen unter Berücksichtigung:
1. dieser Anleitung,
 2. aller anderen zum Antrieb gehörenden Projektierungsunterlagen, Inbetriebnahmeanleitungen und Schaltbilder,
 3. der aktuell gültigen nationalen und regionalen Vorschriften über Sicherheit und Unfallverhütung.

- Warning**
Live or moving parts in electrically driven machines can cause serious or fatal accidents.
Only **qualified personnel** may carry out assembly, connection, commissioning, maintenance and repair work and must observe the following:
1. these instructions,
 2. all other planning documentation, commissioning instructions and circuit diagrams for the drive unit
 3. the applicable regional and national regulations on safety and accident prevention.

2. Allgemeines

WATT - Getriebe (mit Adapter oder Eintriebswelle - geschlossene Ausführung) und Getriebemotoren werden nach den Bestelldaten ausgeführt, sind entsprechend der bestellten Bauform mit Schmiermittel gefüllt und kommen nach einem Probelauf und Überprüfung der Ausführung zur Auslieferung. Wird der Antrieb nicht unmittelbar verwendet, so ist er in trockenen Räumen zu lagern und die Dichtringe sind vor direkter UV Bestrahlung zu schützen.

3. Einbau

Das Getriebe ist mit entsprechenden Hebelmitteln zu transportieren und unbedingt in der bestellten Bauform zu montieren, da die Schmierung und die Getriebeausführung auf die Bauform abgestimmt werden. **Bei Getrieben in denen Entlüftungsschrauben verwendet werden, ist vor Inbetriebnahme die entsprechende Verschlusschraube durch die mitgelieferte Entlüftungsschraube zu ersetzen.** Die richtige Lage der Entlüftungsschraube ist auf den Seiten 7 bis 13 dieser Betriebsanleitung bei den jeweiligen Getriebebauformen mit (E) bezeichnet.

Antriebe, welche ohne Ölfüllung bestellt werden, kommen mit Innenkonservierung zur Auslieferung. Die Innenkonservierung der Getriebe erfolgt mit Korrosionsschutzöl. Das Konservierungsöl ist auf jeden Fall mit der am Typenschild angegebenen Öltype mischbar, sodaß die Getriebe vor der Befüllung nicht ausgespült werden müssen. Bei Lagerung unter Raumbedingungen (max. 25°C (77°F) Umgebungstemperatur, max. 80% rel. Luftfeuchtigkeit) ist ein Innenkorrosionsschutz für 12 Monate wirksam.

Sämtliche außenliegende, blanke Flächen werden von WATT vor der Auslieferung mit Konservierungsmittel behandelt.

Die Aufstellung soll so erfolgen, daß der Antrieb keinen Schwingungen oder Erschütterungen ausgesetzt ist, um dadurch bedingte Geräusentwicklung zu vermeiden. Die Befestigungsfläche muß eben und verwindungssteif sein. Gehäuseverspannungen sind unbedingt zu vermeiden.

Bei Getriebemotoren ist der freie Zutritt der Kühlluft zu gewährleisten.

Getriebe und Getriebemotoren mit **Abtriebshohlwellen** (Aufsteckausführung) sind mit Gewindespindeln auf die Maschinenwelle aufzuziehen. Alle Abtriebshohlwellen sind mit einer Bohrungstoleranz nach ISO H7 ausgeführt. Maschinenwelle vor der Montage reinigen und mit Rostschutzfett einstreichen.

Bei Getrieben mit Hohlwelle für Schrumpfscheibenbefestigung sind bei der Montage der Schrumpfscheibe die **Montagevorschriften des Schrumpfscheibenherstellers zu beachten!** Bei mitgelieferter Schrumpfscheibe befindet sich die Montagevorschrift in der Verpackung der Schrumpfscheibe.

Die Schrumpfscheibenabdeckung ist mit Silikon gegen das Getriebegehäuse abzudichten.

⚠ Achtung! Kein Montagedruck über das Getriebegehäuse, keine Schläge auf die Hohl- bzw. Abtriebswelle!

Zur axialen Fixierung eines Aufsteckgetriebes ist ein entsprechendes Befestigungsset zu verwenden.

Das Reaktionsmoment ist mit einer Drehmomentstütze oder einem Gummipufferset abzufangen (keine starren Verschraubungen).

Bei Verwendung eines Getriebes in Aufsteckausführung mit Abtriebsflansch ist unbedingt darauf zu achten, daß die Befestigungsfläche genau im rechten Winkel zur Maschinenwelle liegt, damit Lagerschäden vermieden werden.

2. General

WATT gear units (with adapter or input shaft - closed design) and geared motors are manufactured to order, filled with lubricant and shipped after a final check and test run. If the gear unit is not intended for immediate use, store it in a dry place protecting the sealing rings on the output shaft from exposure to direct UV light.

3. Installation

Always handle the gear unit with suitable hoisting tackle and install it as ordered because design and lubrication have been tailored specially to the specified mounting position. **If a vent plug is to be used in the gear unit, remove the transport plug before commissioning and replace it with the supplied vent plug.** The correct position for the vent plug in the various models is also shown on pages 7 to 13 of this manual and marked (E)

Gear units that are ordered without oil filling are supplied with internal rust proofing consisting of anti-corrosion oil. The anti-corrosion oil can however be mixed with the recommended lubricant indicated on the nameplate. This means that the unit does not have to be flushed before filling with oil. If stored under normal indoor conditions (max. ambient temperature 25°C (77°F), max. humidity 80%), the anti-corrosion protection is effective for 12 months.

Before shipping units, we protect all unpainted external surfaces with anti-corrosion agent.

When installing please ensure that the unit is not exposed to any shocks or vibrations in order to avoid noise during operation. The mounting surface should be even and torsionally rigid. Distortion of the gear case should also be avoided.

Make sure that cooling air can circulate freely in the geared motors.

Gear units and geared motors with **hollow output shafts** should be mounted to the machine shaft with screw spindles. All hollow shafts have a bore tolerance to ISO H7. Clean the machine shaft before assembling the gear unit and coat it with anti-corrosion grease.

In the case of gear units with a hollow shaft for a shrink disc, follow the **shrink disc manufacturer's mounting instructions.** These instructions are to be found in the disc packaging.

Seal the shrink disc cover from the gear case with silicone.

⚠ Warning! Do not apply any pressure to the gear case when mounting. Do not knock the hollow or output shafts.

To fix shaft-mounted units in the axial direction (if there is no shrink disc), use a suitable disc and screw (fixing kit). Reduce reaction torque with a torque arm or a rubber buffer kit (no rigid joints).

If a shaft-mounted gear unit is used with an output flange, ensure that the mounting surface is exactly at right angles to the machine shaft in order to prevent any damage to the bearing.

4. Elektrischer Anschluß (bei Getriebemotoren)

Der Elektroanschluß darf nur durch einen befugten Elektrofachmann durchgeführt werden!

 Die in der Elektrotechnik gültigen Regeln und Vorschriften, insbesondere hinsichtlich Schutzmaßnahmen sind zu beachten.

Die Vorschriften der örtlichen nationalen Energieversorgungsunternehmen sind ebenso einzuhalten.

Vor Inbetriebnahme ist zu prüfen, ob die Netzspannung und Frequenz mit den angeführten Daten am Motorleistungsschild übereinstimmen.

- Motoranschluß nach Schaltbild vornehmen (siehe Seite 15 und 16);
- sichere Schutzleiterverbindung herstellen;
- eventuell falsche Drehrichtung korrigieren durch Vertauschen von 2 Phasen;
- nicht benötigte Kabeleinführungsöffnungen und den Kasten selbst staub- und wasserdicht verschließen;
- Überbelastung und Phasenausfall durch Schutzschalter vorbeugen;
- vor Inbetriebnahme ist der Isolierwiderstand der Wicklung zu kontrollieren;

 **Achtung!** Ein Motorschutzschalter bzw. ein Schutz mit Überstromrelais zum Schutz der Motorwicklungen ist **unbedingt** zu installieren. Schmelzsicherungen schützen den Motor nicht vor Überlastungen sondern lediglich die Netzleitungen oder Schaltanlagen gegen Schäden bei Kurzschluß.

4.1. Aufstellung und Anschluß des Motors

Die Motoren in Standardausführung sind für den Betrieb bei einer maximalen Umgebungstemperatur von +40°C (104°F) sowie einer Aufstellungshöhe bis 1000m über dem Meeresspiegel geeignet.

Die Aufstellung hat so zu erfolgen, daß der Zutritt von Frischluft und das Abströmen der Warmluft ungehindert erfolgen kann. Es ist verboten den Lüfterflügel und die Lüfterhaube zu entfernen bzw. den Motor in ein Gehäuse einzuschließen, da in beiden Fällen die Kühlluftzufuhr verringert wird. Dadurch würde der Motor überhitzt werden.

Kondenswasserbohrung

Bei Motoren, die starken Temperaturschwankungen oder extremen klimatischen Verhältnissen ausgesetzt sind, empfehlen wir eine Kondenswasserbohrung.

 **Achtung!** Bei Motoren mit Kondenswasserbohrungen ist auf die richtige Einbaulage zu achten!

Temperaturwächter TH

Temperaturwächter sind kleine Bimetallschalter, die beim Überschreiten der Ansprechtemperatur einen Kontakt öffnen oder schließen. Der Öffnungskontakt trennt den Erregerkreis des Motorschützes und die Spannungsversorgung des Motors wird damit getrennt.

Farbe: rot



4. Electrical connection (at geared motors)

Only authorized electricians are permitted to connect electrical systems.

 Observe all rules and regulations governing electrical installations, especially safety precautions.

The national utility regulations for the country concerned also have to be complied with.

Before starting the motor, please check that the mains voltage and frequency correspond to the data on the motor rating plate.

- Connect the motor as in the circuit diagram (see pages 15 and 16)
- Connect the equipment grounding conductor
- Check the motor rotation and correct if necessary by reversing the phases
- Seal any unused cable entries and the terminal box ensuring that it is dust and watertight
- Install a circuit breaker to prevent overloading and phase failure
- Before starting the motor, check the insulation resistance of the winding.

 **Warning!** A motor circuit breaker or contactor with an overcurrent relay **must be installed** to prevent the motor winding from burning out. Fuses **do not** stop the motor overloading, but merely protect the power cables or switchgear from damage in the event of a short circuit.

4.1. Motor installation and connection

Standard motors are suitable for use at a max. ambient temperature of +40°C (104°F) and an altitude of up to 1000m above sea level.

When installing the motor, ensure that the intake is not obstructed and air can circulate freely. Do not remove the fan blade or cowl, or enclose the motor with a casing because in both cases there would not be enough air for cooling and the motor could overheat.

Condensate drain hole

If motors are subject to great fluctuations in temperature or extreme climatic conditions, we recommend using a condensate drain hole.

 **Warning!** Before installing motors with condensate drain holes, check that the mounting position is correct.

Temperature controller TH

Thermostats have small bimetallic strips that make or break a contact when the critical temperature is reached. The break contact opens the field circuit and disconnects the power supply to the motor.

Colour: red

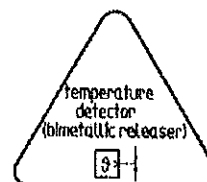

Kalbleitertemperaturfühler TF

Kalbleitertemperaturfühler sind Halbleiter, bei denen der ohmsche Widerstand bei Erreichen der Bemessungsansprechtemperatur extrem ansteigt. Zusätzlich zu den Kalbleiterfühlern ist ein Auslösegerät notwendig. Das im Auslösegerät befindliche Relais mit einem Wechselkontakt kann nach Bedarf zum Unterbrechen des Erregerkreises des Motorschützers oder zum Auslösen eines Warnsignals verwendet werden.

Farbe: gelb



Thermistor protection TF

PTC thermistors are semi-conductors whose electrical resistance increases dramatically when the critical temperature is reached. In addition to the PTC thermistor, a control unit is also required. The relay in the tripping unit has a changeover contact, which can either be used to open the excitation circuit in the motor contactor or trigger a warning signal.

Colour: yellow

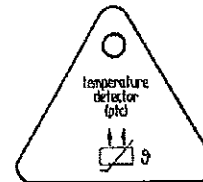

Stillstandsheizung

Bei besonderen Klimaverhältnissen z.B. bei starken Temperaturschwankungen oder bei stillstehenden Motoren in feuchter Atmosphäre kann eine Stillstandsheizung vorgesehen werden. Die Beschaltung des Heizelementes ist im Klemmkasten des Motors ersichtlich.

Anti-condensation heater

Under certain climatic conditions an anti-condensation heater may be required e.g. when there are great fluctuations in temperature or the motor is at rest in a humid atmosphere. For heater connection, see the motor terminal box.



Achtung! Während des Betriebes muß die Stillstandsheizung ausgeschaltet sein.



Warning! The anti-condensation heater must be switched off during normal operation.

Klemmenbezeichnung und Drehsinn

Ständerklemmen siehe Schaltbilder auf den Seite 15 und 16 L1, L2, L3 ... Phasenfolge des Netzes

Bei Anschluß entsprechend den nachstehenden Anschlußdiagrammen (Seite 15 und 16) ergibt sich Rechtslauf des Rotors. Ist dies nicht der Fall, dann sind zwei von den drei Zuleitungen des Anlaßgerätes oder Motors untereinander auszutauschen.

Terminal markings and direction of rotation

For stator terminals, see circuit diagrams on pages 15 and 16 L1, L2, L3 .. Phase sequence in power supply

When connected as illustrated in the following diagrams (pages 15 and 16), the rotor will rotate clockwise. If this is not the case, please change two of the three leads to the starter or motor.

Anschluß

Für den Anschluß der Netzleitungen ist das Schaltbild im Klemmkasten und die Daten auf dem Motorleistungsschild zu beachten.

Bei Motoren mit Y/D Start sind alle Klemmbrettbrücken (Verbindungsbleche) am Klemmbrett zu entfernen und die sechs Klemmen am Anlaßgerät nach Schaltplan anzuschließen. Bei Motoren mit Direktstart (Y od. D) sind die Klemmbrettbrücken am Klemmbrett entsprechend den nachfolgenden Anschlußdiagrammen auf den Seiten 15 und 16 am Motorklemmbrett zu legen.

Connection

When connecting to the power supply, observe the diagram inside the terminal box and the data on the motor rating plate. In the case of motors with Y/D start, remove all terminal links on the board and connect the six terminals to the starter as indicated in the circuit diagram.

For direct start (Y or D) motors, connect the terminal links on the board as shown in the diagrams on pages 15 and 16 below.

5. Montage von Übertragungselementen

Alle Abtriebswellen sind bei Lieferung mit einem Konservierungsmittel versehen, der mit einem üblichen Lösungsmittel zu entfernen ist.

STOP Achtung! Das Lösungsmittel darf nicht an die Dichtlippen der Wellendichtringe kommen!

Die Abtriebswellen sind bis zu einem Durchmesser von 50mm nach Toleranzfeld ISO k6 und ab 55mm nach Toleranzfeld ISO m6 gefertigt.

Alle Abtriebswellen sind mit Zentriergewinden nach DIN 332 Form DR versehen, die zum Aufziehen von Übertragungselementen benutzt werden sollten.

Achtung! Schläge und Stöße auf das Wellenende unbedingt vermeiden, da die Abtriebslagerung dadurch beschädigt werden kann.

Achtung! Mech. Antriebselemente die Radialkräfte auf die Abtriebswelle ausüben sind möglichst nah dem Abtriebslagern zu montieren!

6. Schmierung und Wartung

6.1. bei Stirnrad-, Aufsteck-, Flach-, Kegelflach- und Kegelnstirnradgetriebe

Getriebeeinheiten (mit Adapter oder Eintriebswelle - geschlossene Ausführung) und Getriebemotoren werden betriebsfertig geliefert, befüllt mit Mineralöl, mit der bauförmgerechten Schmierstoffmenge, welche der folgenden Tabelle auf den Seiten 7 bis 12 entnommen werden kann. Standardbefüllung mit Getriebeöl (Schmieröltyp Kennzeichnung nach DIN51502 CLP220, Viskositätsklasse nach ISO VG 220 nach DIN51519) für Umgebungstemperatur -10°C (14°F) bis +40°C (104°F).

Eine besondere Wartung benötigen die Getriebe nicht, diese beschränkt sich auf eine Kontrolle in entsprechenden Zeitabständen. Ein Schmierstoffwechsel soll bei Normalbetrieb alle 10.000 Betriebsstunden oder nach 3 Jahren durchgeführt werden. Bei extremen Betriebsbedingungen und hoher Luftfeuchtigkeit nach 5.000 Stunden. Beim Schmierstoffwechsel Gehäuse mit geeignetem Lösungsmittel sauber auswaschen und alte Schmierstoffrückstände entfernen. Dichtungen prüfen. Keinesfalls verschiedene Schmierstoffe miteinander mischen! Jedes Getriebe ist mit einem Typenschild versehen, auf dem die Ölspezifikation ersichtlich ist.

6.2. bei Stirnradschneckengetriebe

Getriebeeinheiten (mit Adapter oder Eintriebswelle - geschlossene Ausführung) und Getriebemotoren werden betriebsfertig geliefert, befüllt mit synthetischem Schmierstoff, mit der bauförmgerechten Schmierstoffmenge, welche der folgenden Tabelle auf der Seite 13 entnommen werden kann und sind grundsätzlich wartungsfrei. Die Wartung beschränkt sich auf eine Kontrolle in ausreichenden Zeitabständen. Ein Schmierstoffwechsel soll bei Normalbetrieb alle 20.000 Betriebsstunden oder nach 4 - 5 Jahren durchgeführt werden. Bei extremen Betriebsbedingungen und hoher Luftfeuchtigkeit nach 10.000 Stunden. Beim Schmierstoffwechsel Gehäuse mit geeignetem Lösungsmittel sauber auswaschen und alte Schmierstoffrückstände entfernen. Dichtungen prüfen. Keinesfalls verschiedene Schmierstoffe miteinander mischen! Jedes Getriebe ist mit einem Typenschild versehen, auf dem die Ölspezifikation ersichtlich ist.

STOP Achtung! Synthetische Schmiermittel niemals untereinander oder mit mineralischen Schmierstoffen mischen!

5. Mounting transmission devices

All output shafts are supplied with an anti-corrosion coating that has to be removed using a standard solvent.

STOP Warning! The solvent must not come into contact with the shaft sealing ring!

The output shafts are manufactured to tolerance zone ISO k6 up to a diameter of 50mm and to ISO m6 over 55mm.

All output shafts are machined with tapped center holes for mounting transmission devices to DIN 332 Shape DR.

Warning! Do not subject the output shaft to knocks or shocks because they could damage the bearings.

Warning! Mount mechanical components that exert radial forces on the output shaft such as sprockets as close as possible to the output bearing.

6. Lubrication and maintenance

6.1. Helical, shaft mounted, parallel shaft, angle parallel shaft and helical bevel gear units

Gear units (with adapter or input shaft - closed design) and geared motors are supplied ready for use and filled with the correct volume of mineral oil for the required mounting position (see tables on pages 7 to 12 below). Standard lubrication is with gear oil (oil type as per DIN 51502 CLP220, viscosity class as per ISO VG220 to DIN 51502) for ambient temperatures from -10°C (14°F) to +40°C (104°F).

The gear units do not require any special maintenance, but should simply be checked at suitable intervals. Under normal conditions the lubricant should be changed every 10,000 operating hours or every 3 years and if subject to extreme conditions and high humidity every 5,000 operating hours. When changing the lubricant, clean the case with a suitable solvent and remove any residue. Check the seals. Do not mix different types of lubricant. Every gear unit has a nameplate indicating the recommended lubricant.

6.2. Helical worm gear units

Gear units (with adapter or input shaft - closed design) and geared motors are supplied ready for use and filled with the correct volume of synthetic lubricant for the required mounting position (see tables on page 13 below). They are basically maintenance-free, but should be checked at suitable intervals. Change the lubricant every 20,000 operating hours or every 4 - 5 years under normal conditions and every 10,000 operating hours if subject to extreme conditions or high humidity. When changing the lubricant, clean the case with a suitable solvent and remove any residues. Check the seals. Do not mix different types of lubricant. Every gear unit has a nameplate indicating the recommended lubricant.

STOP Warning! Never mix synthetic lubricants with other synthetic or mineral lubricants!

Die genauen Ölmengen sind auf den Typenschildern der Antriebe angegeben.
Die auf den nachfolgenden angeführten Ölmengen Seite 7-13 in Liter sind Anhaltswerte.

For the exact volume of oil, see the gear unit nameplate.
The oil volumes indicated in liters on pages 7-13 below are only a guideline.

7. Montage und Demontage eines Getriebes mit Hohlwelle

7. Assembling and dismantling a gear unit with hollow shaft

**Montage
Assembling**

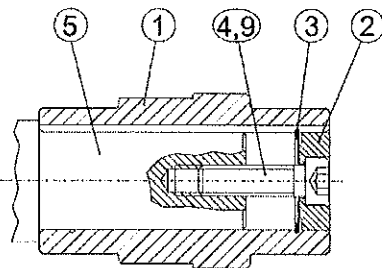

**Demontage
Dismantling**

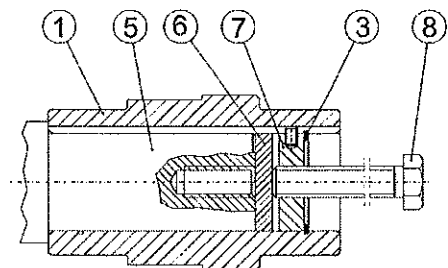

- 1) Hohlwelle
- 2) Scheibe
- 3) Sicherungsring DIN 472
- 4) Zylinderschraube DIN 6912 ((kundenbezogen, Länge der Schraube entsprechend der Maschinenwellenlänge)
- 5) Kundenwelle *)
- 6) Druckscheibe
- 7) Abdrückmutter
- 8) Abdrückschraube
- 9) Zylinderschraube DIN 6912 (Inhalt des Befestigungssets für die WATT-Einsteckwelle)

- 1) Hollow shaft
- 2) Disc
- 3) Circlip DIN 472
- 4) Socket head screw DIN 6912 (to customer specification, length according to machine shaft length)
- 5) Customer's shaft *)
- 6) Thrust washer
- 7) Jack nut
- 8) Jack screw
- 9) Socket head screw DIN 6912 (part of fixing kit for WATT insert shaft)

Montage:

Getriebe mit Hohlwelle auf die Maschinenwelle aufziehen (z.B.: mit Gewindespindel oder Hydraulikvorrichtung). Sicherungsring Pos.3 und Scheibe Pos.2 in die Hohlwelle einsetzen und mit Schraube Pos.4 fixieren.

Assembling:

Mount the gear unit with hollow shaft on the machine shaft (e.g. with screw spindle or hydraulic device). Insert the circlip (3) and disc (2) in the hollow shaft and fix in place with the screw (4).

Demontage:

Schraube Pos.4, Scheibe Pos.2 und Sicherungsring Pos.3 entfernen, Druckscheibe Pos. 6 und Abdrückmutter Pos.7 in die Hohlwelle geben, Sicherungsring einsetzen und mit Abdrückschraube Pos.8 das Getriebe von der Welle abdrücken.

Dismantling:

Remove the screw (4), disc (2) and circlip (3), place the thrust washer (6) and jack nut (7) in the hollow shaft, insert the circlip and remove the gear unit from the shaft with jack screw (8).

Die Teile 4, 6, 7 und 8 sind nicht in unserem Lieferumfang. Die Teile 2, 3 und 9 sind im Befestigungsset GMBSBSD enthalten.

Parts 4, 6, 7 and 8 are not supplied with the gear unit. Parts 2, 3 and 9 are included in fixing kit GMBSBSD

*) mit Zentriergewinde nach DIN332, Bl.2 Form DR

*) with center hole as per DIN332, p.2 Shape DR

**6.1.1. STIRNRADGETRIEBE
 (GETRIEBEMOTOREN)**

**6.1.1. HELICAL GEAR UNITS
 (GEARED MOTORS)**

BAUFORMEN

MOUNTING POSITIONS

KLEMMKASTENLAGE (A,B,C,D) und KABELINFÜHRUNG (I,II,III)
 POSITION of TERMINAL BOX (A,B,C,D) and CABLE ENTRY (I,II,III)

B3/B5

B6

B7

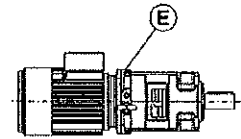
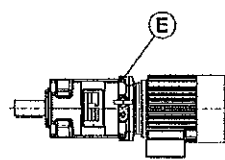
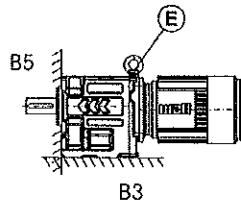
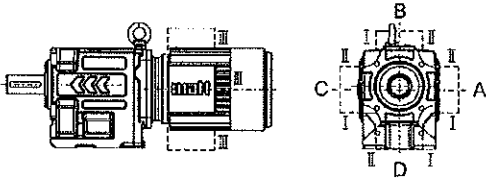

B8

V1/V5

V3/V6

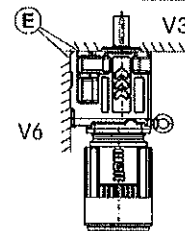
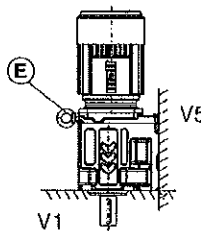
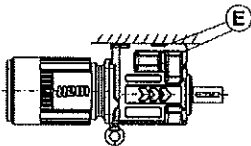

(E) ... Entlüftungsschraube / vent plug

Bei Getriebetypen H40, H50, H55, H60, H65 -
 werden bei jeder Einbaulage im Standard keine
 Entlüftungsschrauben verwendet.

Gear unit sizes H40, H50, H55, H60, H65 -
 no vent plugs used in any mounting position as stan-
 dard.

SCHMIERSTOFFMENGEN

LUBRICANT CAPACITY

Stirnradgetriebe Helical gear units:		Bauformen / Mounting positions					
		B3/B5	B6	B7	B8	V1/V5	V3/V6
Type							
2-stufig 2-stage	H.40A			0,3 l			0,5 l
	H.50A			0,55 l			0,7 l
	H.55A			0,65 l			0,9 l
	H.60A			0,85 l			1,1 l
	H.65A	≤WAR114		1,1 l			1,2 l
	H.65A	≥WAR134		1,3 l			1,6 l
	H.70A	≤WAR114		1,5 l			1,8 l
	H.70A	≥WAR134		1,8 l			2,3 l
3-stufig 3-stage	H.80A	≤WAR114	2,0 l				2,5 l
	H.80A	≥WAR134	2,3 l				3,0 l
	H.85A	≤WAR114	2,4 l				3,0 l
	H.85A	≥WAR134	2,7 l				3,4 l
	H.50C			0,9 l			1,1 l
	H.55C			1,0 l			1,2 l
	H.60C			1,2 l			1,4 l
4-st. 4-st.	H.65C		1,3 l				1,6 l
	H.70C		1,8 l				2,3 l
	H.80C		2,6 l				3,4 l
	H.85C		2,8 l				3,8 l
	H.70D			2,5 l			
H.80D			3,6 l				
H.85D			4,2 l				

Bei Anbau eines Adapters sind folgende Mindestmengen zu berücksichtigen:

If an adapter is mounted, please note the following reductions in lubricant volume:

IEC/AD 63-90 WN 4-6	IEC/AD 101-112 WN 7-8	IEC/AD 132	IEC/AD 160-180	IEC/AD 200-225
-0,1 l	-0,2 l	-0,4 l	auf Anfrage / on request	

**6.1.2. EINSTUFIGE STIRNRADGETRIEBE
 (GETRIEBEMOTOREN)**

**6.1.2. SINGLE STAGE HELICAL GEAR UNIT
 (GEARED MOTORS)**

BAUFORMEN

MOUNTING POSITIONS

KLEMMKASTENLAGE (A,B,C,D) und KABELINFÜHRUNG (I, II, III)
 POSITION of TERMINAL BOX (A,B,C,D) and CABLE ENTRY (I, II, III)

B3/B5

B6

B7

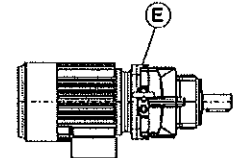
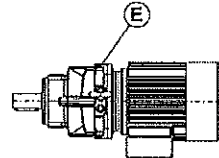
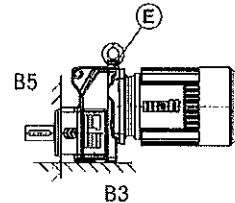
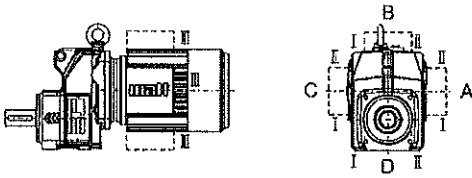

B8

V1/V5

V3/V6

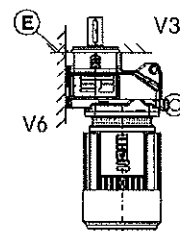
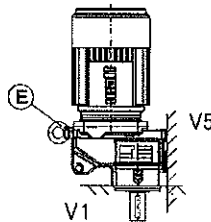
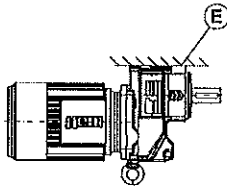

(E) ... Entlüftungsschraube / vent plug

Bei Getriebetypen H40E, H50E, H60E -
 werden bei jeder Einbaulage im Standard keine
 Entlüftungsschrauben verwendet.

Gear unit sizes H40E, H50E, H60E -
 no vent plugs used in any mounting position as stan-
 dard.

SCHMIERSTOFFMENGEN

LUBRICANT CAPACITY

Einstufige Getriebe
 Single stage gear
 units:

Bauformen / Mounting positions

Type	B3/B5	B6	B7	B8	V1/V5	V3/V6
H.40E				0,3 l		
H.50E				0,35 l		
H.60E	≤WAR 114			0,6 l		
	≥WAR 134			0,9 l		
H.70E	≤WAR 114			1,0 l		
	≥WAR 134			1,3 l		
H.80E	≤WAR 114			1,5 l		
	≥WAR 134			1,8 l		

Bei Anbau eines Adapters sind folgende Mindermengen zu berücksichtigen:

If an adapter is mounted, please note the following reductions in lubricant volume:

IEC/AD 63-90 WN 4-6	IEC/AD 101-112 WN 7-8	IEC/AD 132	IEC/AD 160-180	IEC/AD 200-225
-0,1 l	-0,2 l	-0,4 l	auf Anfrage / on request	

**6.1.3. AUFSTECKGETRIEBE
 (GETRIEBEMOTOREN)**

**6.1.3. SHAFT MOUNTED GEAR UNITS
 (GEARED MOTORS)**

BAUFORMEN

MOUNTING POSITIONS

KLEMMKASTENLAGE (1,2,3,4) und KABELINFÜHRUNG (I,II,III)
 POSITION OF TERMINAL BOX (1,2,3,4) and CABLE ENTRY (I,II,III)

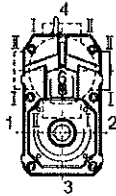
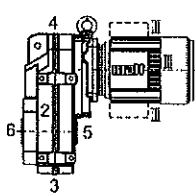

H3..

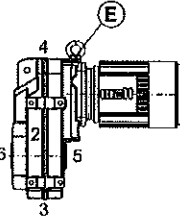

H4..

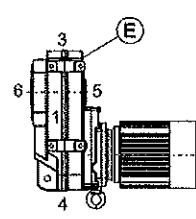

H1..

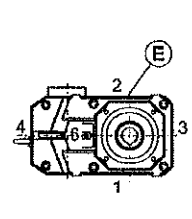

H2..

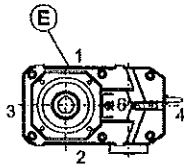

V5..

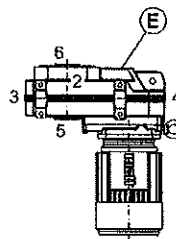

V6..

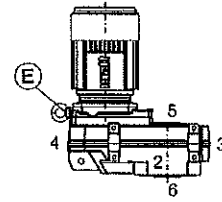

(E) ... Entlüftungsschraube / vent plug

Bei Getriebetypen A40, A45, A55, A65 -
 werden bei jeder Einbaulage im Standard keine
 Entlüftungsschrauben verwendet.

Gear unit sizes A40, A45, A55, A65 -
 no vent plugs used in any mounting position as standard.

SCHMIERSTOFFMENGEN

LUBRICANT CAPACITY

Aufsteckgetriebe Shaft mounted gear units:		Bauformen / Mounting positions					
		H1	H2	H3	V6	H4	V5
2-stufig 2-stage	AS.40A			0,6 l			0,8 l
	AS.45A			0,9 l			1,1 l
	AS.55A		0,9 l			1,2 l	
	AS.65A ≤WAR 114		1,7 l			2,5 l	
	AS.65A ≥WAR 134		2,0 l			2,8 l	
	AS.75A ≤WAR 114		3,0 l			4,5 l	
	AS.75A ≥WAR 134		3,2 l			5,0 l	
	AS.85A ≤WAR 114		5,6 l			9,0 l	
AS.85A ≥WAR 134		5,9 l			9,6 l		
3-stufig 3-stage	AS.55C		1,1 l			1,6 l	
	AS.65C		2,0 l			3,2 l	
	AS.75C		3,2 l			5,5 l	
	AS.85C		5,9 l			10,0 l	
4-st. 4-st.	AS.75D		3,5 l			6,0 l	
	AS.85D		6,2 l			10,8 l	

Bei Anbau eines Adapters sind folgende Mindestmengen zu berücksichtigen:

If an adapter is mounted, please note the following reductions in lubricant volume:

IEC/AD 63-90 WN 4-6	IEC/AD 101-112 WN 7-8	IEC/AD 132	IEC/AD 160-180	IEC/AD 200-225
-0,1 l	-0,2 l	-0,4 l	auf Anfrage / on request	

**6.1.4. FLACHGETRIEBE
 (GETRIEBEMOTOREN)**

**6.1.4. PARALLEL SHAFT GEAR UNITS
 (GEARED MOTORS)**

BAUFORMEN

MOUNTING POSITIONS

KLEMMKASTENLAGE (1,2,3,4) und KABELEINFÜHRUNG (I, II, III)
 POSITION OF TERMINAL BOX (1,2,3,4) and CABLE ENTRY (I, II, III)

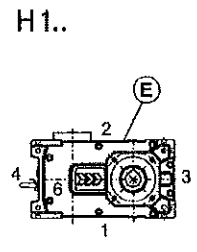
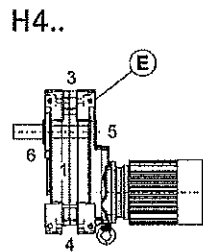
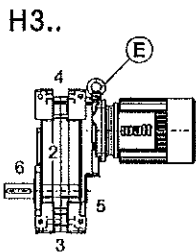
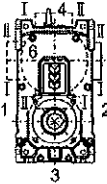
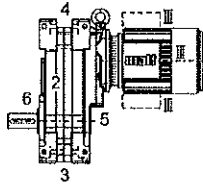

H2..

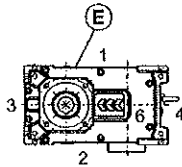

V5..

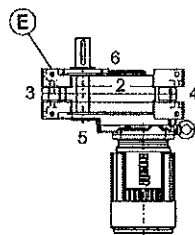

V6..

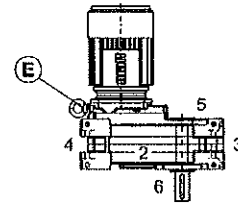

(E) ... Entlüftungsschraube / vent plug

Bei Getriebetypen F55, F65 -
 werden bei jeder Einbaulage im Standard keine
 Entlüftungsschrauben verwendet.

Gear unit sizes F55, F65 -
 no vent plugs used in any mounting position as stan-
 dard.

SCHMIERSTOFFMENGEN

LUBRICANT CAPACITY

Flachgetriebe
 Parallel shaft gear
 units:

Bauformen / Mounting positions

Type	H1	H2	H3	V5	H4	V6
2-stufig 2-stage						
FU.55A	0,9 l		1,2 l		1,4 l	
FU.65A ≤WAR114	1,8 l		2,3 l		2,8 l	
≥WAR134	2,2 l		2,7 l		3,2 l	
FU.75A ≤WAR114	3,1 l		4,0 l		5,0 l	
≥WAR134	3,4 l		4,3 l		5,5 l	
FU.85A ≤WAR114	5,8 l		7,5 l		9,8 l	
≥WAR134	6,2 l		8,0 l		10,3 l	
3-stufig 3-stage						
FU.55C	1,1 l		1,6 l		1,8 l	
FU.65C	2,1 l		3,0 l		3,4 l	
FU.75C	3,4 l		5,0 l		5,8 l	
FU.85C	6,0 l		9,0 l		10,8 l	
4-st. 4-st.						
FU.75D		4,5 l			6,2 l	
FU.85D		8,5 l			11,2 l	

Bei Anbau eines Adapters sind folgende Mindestmengen zu berücksichtigen:

If an adapter is mounted, please note the following reductions in lubricant volume:

IEC/AD 63-90 WN 4-6	IEC/AD 101-112 WN 7-8	IEC/AD 132	IEC/AD 160-180	IEC/AD 200-225
-0,1 l	-0,2 l	-0,4 l	auf Anfrage / on request	

**6.1.5. KEGELSTIRNRADGETRIEBE
 (GETRIEBEMOTOREN)**

**6.1.5. HELICAL BEVEL GEAR UNITS
 (GEARED MOTORS)**

BAUFORMEN

MOUNTING POSITIONS

KLEMMKASTENLAGE (1,2,3,4) und KABELINFÜHRUNG (I, II, III)
 POSITION OF TERMINAL BOX (1,2,3,4) and CABLE ENTRY (I, II, III)

H3..

H4..

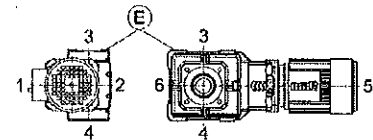
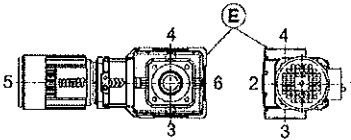
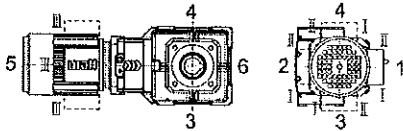

H5..

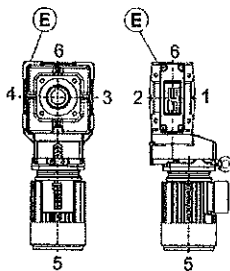

H6..

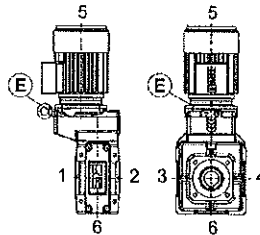

V1..

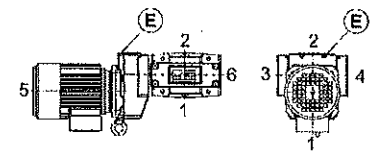

V2..

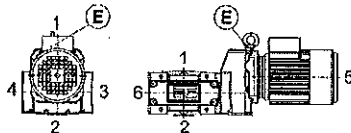

ⓔ ... Entlüftungsschraube / vent plug

Bei Getriebetypen K40, K50, K60 -
 werden bei jeder Einbaulage im Standard keine
 Entlüftungsschrauben verwendet.

Gear unit sizes K40, K50, K60 -
 no vent plugs used in any mounting position as stan-
 dard.

SCHMIERSTOFFMENGEN

LUBRICANT CAPACITY

Kegelstirnrad- getriebe Helical bevel gear units: Type	Bauformen / Mounting positions					
	H3	H4	V1	V2	H5	H6
2-stufig 2-stage						
K.40A	0,7 l			1,0 l		
K.50A	0,8 l			1,2 l		
K.60A ≤WAR114	1,4 l			2,0 l		
K.60A ≥WAR134	1,6 l			2,3 l		
K.70A	auf Anfrage / on request			auf Anfrage / on request		
K.80A	auf Anfrage / on request			auf Anfrage / on request		
3-stufig 3-stage						
K.50C	1,0 l			1,5 l		
K.60C	1,6 l			2,4 l		
K.70C	auf Anfrage / on request			auf Anfrage / on request		
K.80C	auf Anfrage / on request			auf Anfrage / on request		
4-st. 4-stage						
K.70D	auf Anfrage / on request			auf Anfrage / on request		
K.80D	auf Anfrage / on request			auf Anfrage / on request		

Bei Anbau eines Adapters sind folgende Mindestmengen zu berücksichtigen:

If an adapter is mounted, please note the following reductions in lubricant volume:

IEC/AD 63-90 WN 4-6	IEC/AD 101-112 WN 7-8	IEC/AD 132	IEC/AD 160-180	IEC/AD 200-225
-0,1 l	-0,2 l	-0,4 l	auf Anfrage / on request	

**6.1.6. KEGELFLACHGETRIEBE
 (GETRIEBEMOTOREN)**

**6.1.6. ANGLE PARALLEL SHAFT GEAR UNITS
 (GEARED MOTORS)**

BAUFORMEN

MOUNTING POSITIONS

KLEMMKASTENLAGE (I,2,5,6) und KABELEINFÜHRUNG (I,II,III)
 POSITION of TERMINAL BOX (1,2,5,6) and CABLE ENTRY (I,II,III)

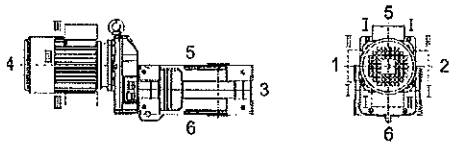

H3..

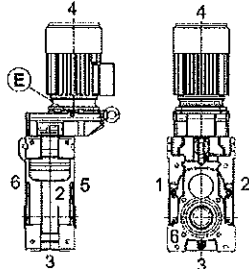

H4..

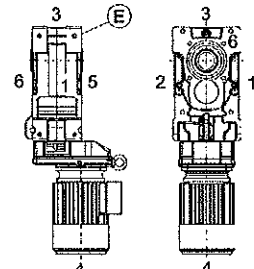

Lage des Vorsatzgetriebes nach Seite 2 oder 5
 Position of primary gear unit towards side 2 or 5

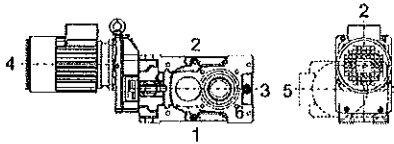

H1..

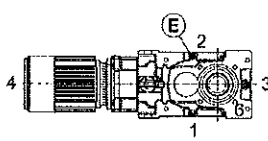

H2..

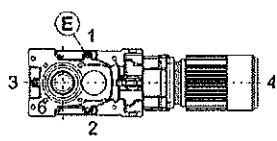

V5..

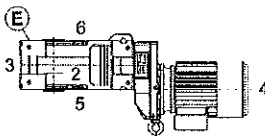

V6..

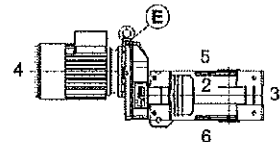

(E) ... Entlüftungsschraube / vent plug

Bei allen Getriebetypen werden bei jeder Einbaulage im Standard Entlüftungsschrauben verwendet.

All helical worm gear units have vent plugs in all mounting positions as standard.

SCHMIERSTOFFMENGEN

LUBRICANT CAPACITY

Kegelflachgetriebe
 Angle parallel shaft gear units:

Bauformen / Mounting positions

Type	H1	H2	V5	H3	H4	V6
2-stufig 2-stage	C.70A ≤WAR 114 ≥WAR 134	2,1 l 2,3 l			2,9 l 3,2 l	
	C.80A ≤WAR 114 ≥WAR 134		auf Anfrage / on request			
3-st. 3-sl.	C.70C C.80C	2,4 l			3,5 l	
			auf Anfrage / on request			
4-st. 4-sl.	C.70D C.80D	2,7 l			3,9 l	
			auf Anfrage / on request			

Bei Anbau eines Adapters sind folgende Mindestmengen zu berücksichtigen:

If an adapter is mounted, please note the following reductions in lubricant volume:

IEC/AD 63-90 WN 4-6	IEC/AD 101-112 WN 7-8	IEC/AD 132	IEC/AD 160-180	IEC/AD 200-225
-0,1 l	-0,2 l	-0,4 l	auf Anfrage / on request	

**6.2.1. STIRNRADSCHNECKENGETRIEBE
 (GETRIEBEMOTOREN)**

**6.2.1. HELICAL WORM GEAR UNITS
 (GEARED MOTORS)**

BAUFORMEN

MOUNTING POSITIONS

KLEMMKASTENLAGE (1,2,3,4) und KABELINFÜHRUNG (I, II, III)
 POSITION of TERMINAL BOX (1,2,3,4) and CABLE ENTRY (I, II, III)

H3..

H4..

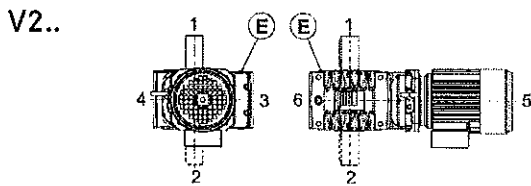
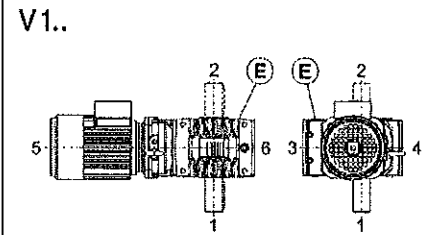
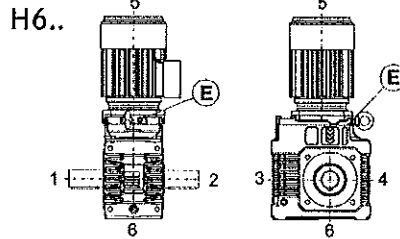
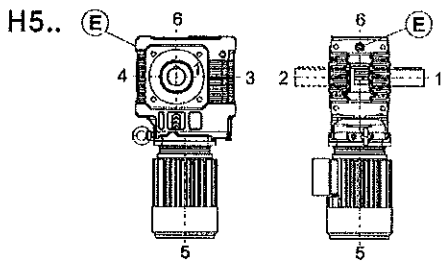
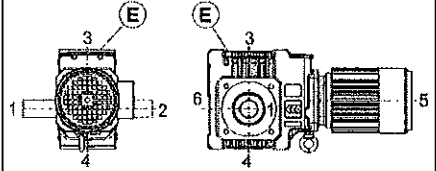
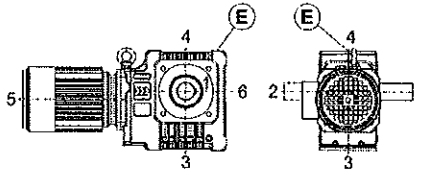
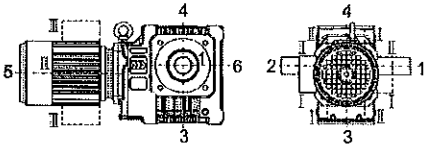

ⓔ ... Entlüftungsschraube / vent plug

Bei allen Getriebetypen werden bei jeder Einbaulage im Standard Entlüftungsschrauben verwendet.

All helical worm gear units have vent plugs in all mounting positions as standard.

SCHMIERSTOFFMENGEN

LUBRICANT CAPACITY

Schneckengetriebe Helical worm gear units:		Bauformen / Mounting positions					
		H3	V1	V2	H6	H5	H4
2-stufig 2-stage	SU.404A,B		0,4 l				0,5 l
	SU.454A,B		0,4 l				0,5 l
	SU.455A,B		0,55 l				0,65 l
	SU.506A,B		0,8 l			1,2 l	
	SU.507A,B		0,9 l			1,3 l	
	SU.608A,B		1,5 l		2,1 l		1,9 l
	SU.609A,B		1,7 l		2,4 l		2,1 l
3-stufig 3-stage	SU.506C		1,2 l			1,5 l	
	SU.507C		1,3 l			1,6 l	
	SU.608C		1,7 l		2,5 l		2,3 l
	SU.609C		1,9 l		2,8 l		2,5 l

Bei Anbau eines Adapters sind folgende Mindestmengen zu berücksichtigen:

If an adapter is mounted, please note the following reductions in lubricant volume:

IEC/AD 63-90 WN 4-6	IEC/AD 101-112 WN 7-8	IEC/AD 132	IEC/AD 160-180	IEC/AD 200-225
-0,1 l	-0,2 l	-0,4 l	auf Anfrage / on request	

8. Schmierstoffempfehlung

8. Recommended lubricants

Für Stirnrad-, Aufsteck-, Flach-, Kegelflach- und Kegelstirnradgetriebe bei einer Umgebungstemperatur: -10°C bis +40°C (14°F bis 104°F)

For helical, shaft mounted, parallel shaft, angle parallel shaft and helical bevel gear units at ambient temperature: -10°C up to +40°C (14°F up to 104°F)

	Degol BG 220
	Energol GR-XP 220
	ALPHA SP 220
	Spartan EP 220
	Klüberoil GEM 1-220
	Mobilgear 630
	Shell Omala OIL 220

Synthetisches Schmiermittel für Stirnrad-schneckengetriebe bei einer Umgebungstemperatur: -10°C bis +40°C (14°F bis 104°F)

Synthetic lubricant for helical worm gear units at ambient temperature: -10°C up to +40°C (14°F up to 104°F)

	Degol GS 460
	Alpha SYN PG 460
	Glycolube S460
	Glygoyle HE 460
	Tivela OIL SD

Keinesfalls verschiedene Schmierstoffe miteinander mischen!

Do not mix different types of lubricant.

Schmiermittel für abweichende Umgebungsbedingungen auf Anfrage.
 Lebensmittelverträgliche und biologische abbaubare Schmiermittel auf Anfrage.

Lubricants for other ambient conditions on request.
 Food proofed and biodegradable lubricants on request.

9. Schaltungsschema für Drehstrommotoren

9. Three phase motors connecting diagrams

9.1. Stern- und Dreieckschaltung für Motoren mit einer Drehzahl:

9.1. Star and delta connection for single speed motors:

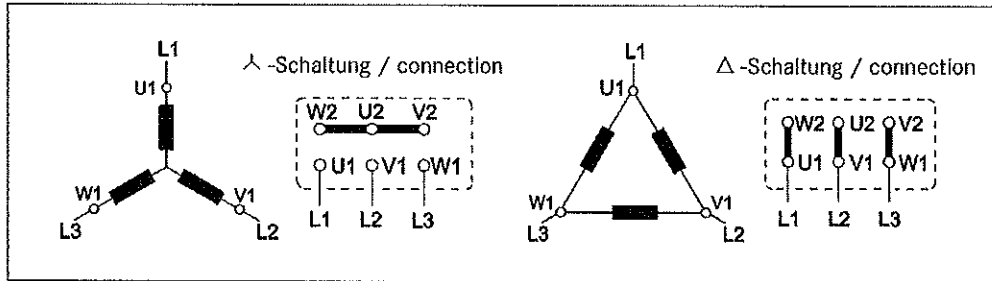

9.1.1. Klemmen - Anschluß für EUSAS - Motoren bis inkl. 2,2kW :

9.1.1. Terminal connections for EUSAS - motors up to 2.2kW

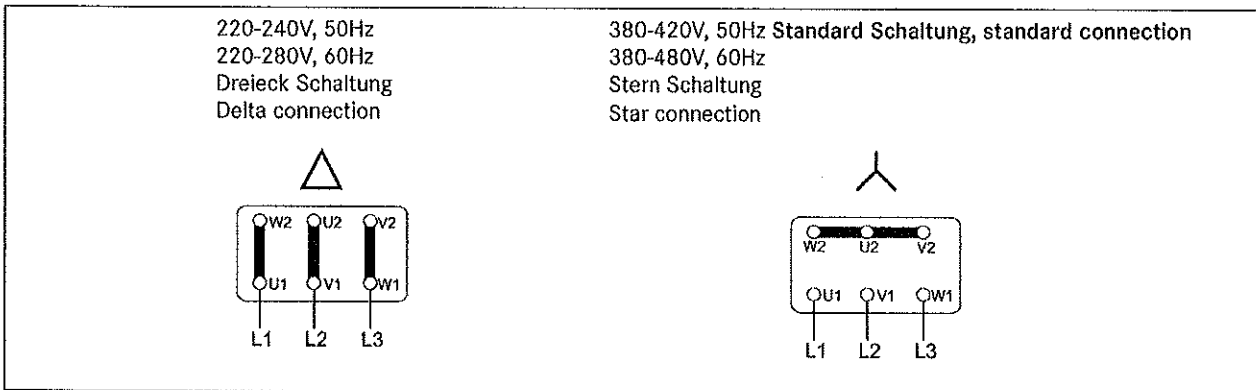

9.1.2. Klemmen - Anschluß für EUSAS - Motoren über 3kW : (bis Baugröße 160)

9.1.2. Terminal connections for EUSAS - motors over 3.0kW: (up to size 160)

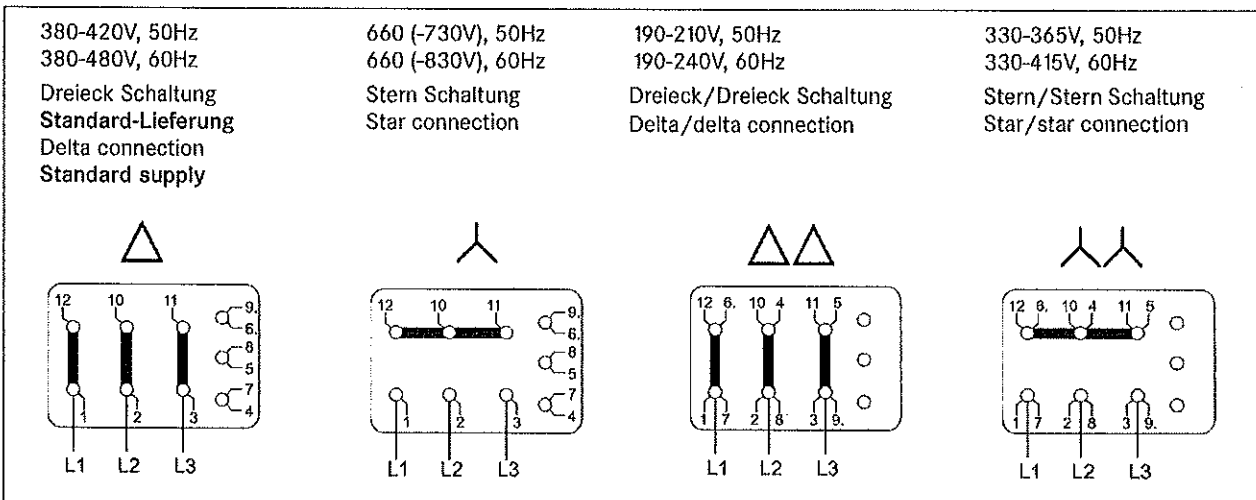

9.1.3. Klemmen - Anschluß für EUSAS -
 Motoren Baugröße 180 -225 :

9.1.3. Terminal connections for EUSAS -
 motor sizes 180 - 225:

380-420V, 50Hz
 380-480V, 60Hz
 Dreieck Schaltung
 Standard-Lieferung
 Delta connection
 Standard supply

660 (-730V), 50Hz
 660 (-830V), 60Hz
 Stern Schaltung
 Star connection

190-210V, 50Hz
 190-240V, 60Hz
 Dreieck/Dreieck Schaltung
 Delta/delta connection

330-365V, 50Hz
 330-415V, 60Hz
 Stern/Stern Schaltung
 Star/star connection

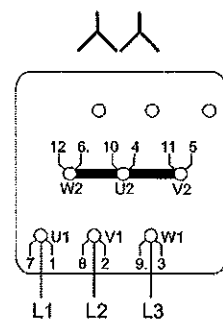
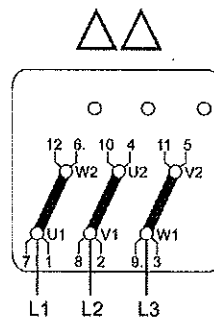
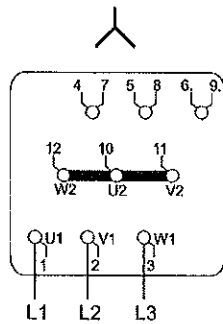
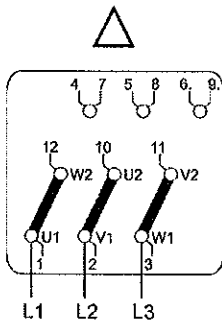

9.2. Schaltung für Motoren mit zwei Drehzahlen
 und zwei getrennten Wicklungen:

9.2. Circuit for two speed motors with two
 separate windings:

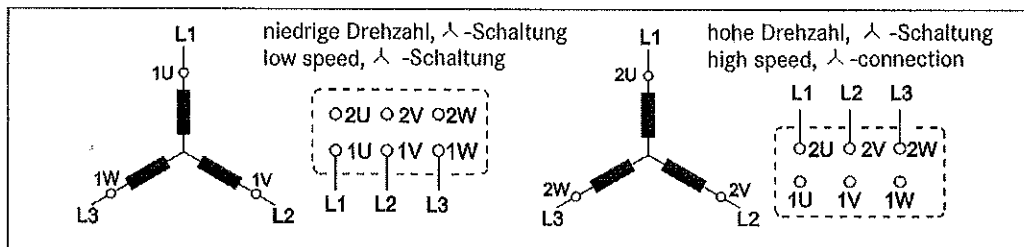

9.3. Dahlanderschaltung für Motoren mit zwei
 Drehzahlen und konstantem Drehmoment:

9.3. Dahlander circuit for two speed motors with
 constant torque:

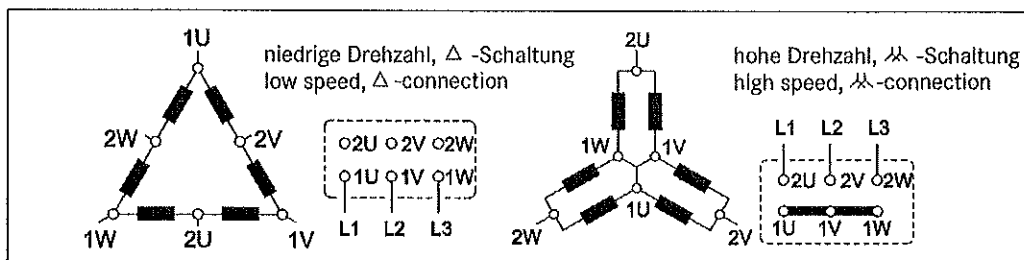

9.4. Dahlanderschaltung für Motoren mit zwei
 Drehzahlen und quadratischem Drehmoment:

9.4. Dahlander circuit for two speed motors with
 square torque:

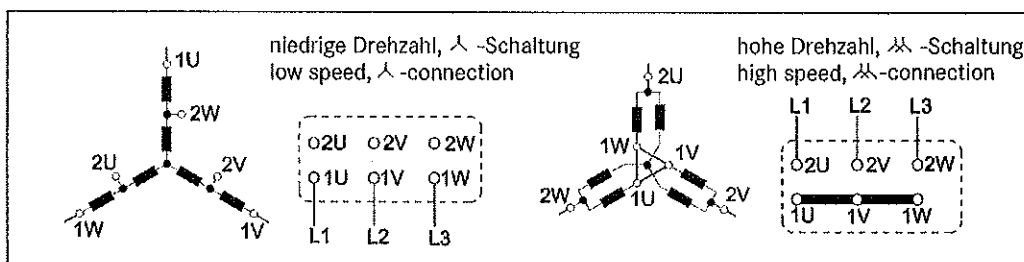

10. Technische Beschreibung - Bremsen

10. Technical specifications - brake

10.1. Wartung

Die WATT-Federdruckbremsen sind nahezu wartungsfrei. Es ist zu empfehlen, den Luftspalt "a" in bestimmten Zeitabständen zu überprüfen, um ein sicheres Lüften der Bremse zu gewährleisten. Ein erforderliches Einstellen des Luftspaltes "a" kann nach Tabelle 1 erfolgen.

10.1. Maintenance

The WATT spring-loaded brakes hardly need any maintenance. However we recommend checking air gap "a" periodically to ensure safe brake release. Adjust air gap "a" to the figures given in table 1 below if necessary.

10.2. Einstellung

Die Bremsen sind bei der Lieferung auf das Nennmoment M_B eingestellt.

10.2. Adjustment

The brakes are set to torque M_B on delivery M_B .

Tabelle 1

Table 1

M_B	[Nm]	2	5	10	20	40	60	100	150	250	500
P_{20}	[W]	22	22	28	34	42	50	64	76	100	125
J_B	[kgm ²] x 10 ⁻³	0,015	0,015	0,045	0,172	0,45	0,86	1,22	2,85	6,65	13,3
P_R	[J/s]	80	80	100	130	160	200	250	300	350	700
W_{Rmax}	[J] x 10 ³	3	3	6	12	25	35	50	75	105	210
W_{RN}	[J] x 10 ⁷	5	5	12	20	35	60	125	200	340	680
a_{normal}	[mm]	0,2	0,2	0,2	0,3	0,3	0,3	0,4	0,4	0,5	0,6
$a_{max.}$	[mm]	0,7	0,7	0,8	0,8	0,9	1,0	1,1	1,1	1,2	1,1
b_{min}	[mm]	4,5	4,5	5,5	7,5	9,5	11,5	12,5	14,5	16,5	16,5
Gewicht / weight	[kg]	1,0	1,0	1,9	3,1	4,6	6,3	10	14,7	21,5	28
t_1	[ms]	35	35	45	60	80	120	160	200	220	220
$t_2 \approx$	[ms]	70	70	95	140	175	210	280	350	500	500
$t_2 =$	[ms]	30	30	45	60	75	90	120	150	180	180

M_B	Bremsmoment	Braking torque
P_{20}	Leistung	Power
J_B	Massenträgheitsmoment Bremse	Brake mass moment of inertia
P_R	Wärmebelastung	Thermal load
W_{Rmax}	Reibarbeit je Schaltspiel	Friction per operating cycle
W_{RN}	Reibarbeit bis zum Nachstellen	Friction until readjustment
a_{normal}	Luftspalt	Air gap
$a_{max.}$	max. Nachstellung	Max. readjustment
b_{min}	Belagstärke min.	Min. lining thickness
t_1	Einschaltzeit	Make time
$t_2 \approx$	Ausschaltzeit	Break time A.C.
$t_2 =$	Ausschaltzeit	Break time D.C.

10.3. Nachstellung des Bremsluftspaltes

Zuerst werden die drei Befestigungsschrauben (13) eine halbe Umdrehung gelöst. Nun lassen sich die Hülsenschrauben (26) durch Drehen gegen den Uhrzeigersinn in den Magnetkörper (12) hineindrehen. Durch Drehen der drei Befestigungsschrauben (13) im Uhrzeigersinn läßt sich der Magnetkörper (12) in Richtung Ankerscheibe (25) so weit bewegen, bis der Nennluftspalt (Tabelle 1) erreicht ist. Jetzt werden die drei Hülsenschrauben wieder im Uhrzeigersinn bis zur festen Anlage aus dem Magnetkörper (12) herausgeschraubt und die Befestigungsschrauben (13) nachgezogen. Der Luftspalt muß jetzt noch auf Gleichmäßigkeit mit einer Fühlerlehre kontrolliert und gegebenenfalls korrigiert werden.

10.3. Readjusting the air gap

First undo the three fixing screws (13) a half turn. The sleeve screws (26) can then be inserted into the magnet body (12) by turning them anti-clockwise. By turning the three fixing screws (13) clockwise, the magnet body (12) can be moved towards the armature (25) until the nominal air gap (Table 1) is reached. Now undo the three sleeve screws again by turning them clockwise out of the magnet body (12) and retighten the fixing screws (13). Check that the air gap is symmetrical with a feeler gauge and adjust if necessary.

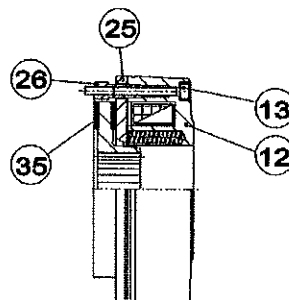

11. Gleichrichter

11. Rectifier

11.1. Einweggleichrichter

11.1. Half-wave rectifier

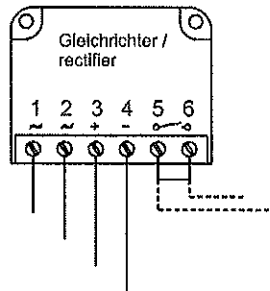

Anschlüsse:

- 1,2: Anschlußspannung (V~)
- 3,4: Ausgangsgleichspannung (V=)
- 5,6: Kontakt für gleichstromseitiges Schalten

Connections:

- 1,2: Connection voltage (A.C. V~)
- 3,4: Output voltage (D.C. V=)
- 5,6: Connection for D.C.-side switching

Schaltbeispiel 1) für Motoren in Dreieckschaltung -
 "gleichstromseitiges Schalten"

Connection example 1) for motors in delta-connection -
 "switching in DC circuit"

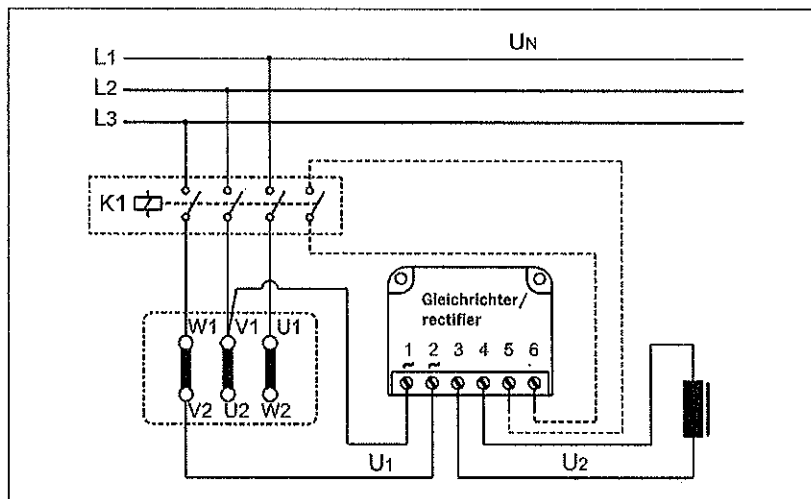

Schaltbeispiel 1) für Motoren in Dreieckschaltung -
 "wechselstromseitiges Schalten"

Example 1) for delta connection motors -
 "switching in AC circuit"

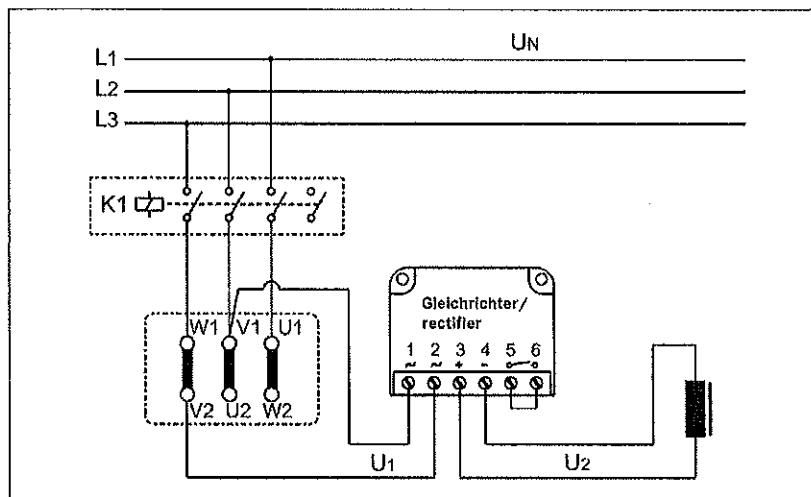

Schaltbeispiel 2) für Motoren in Sternschaltung -
 "gleichstromseitiges Schalten"

Connection example 2) for motors in star-connection -
 "switching in DC circuit"

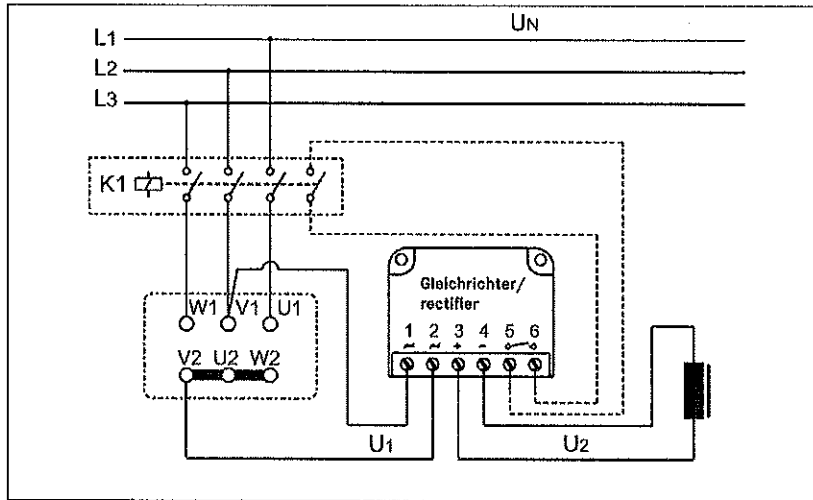

Schaltbeispiel 2) für Motoren in Sternschaltung -
 "wechselstromseitiges Schalten"

Example 2) for star connection motors -
 "switching in AC circuit"

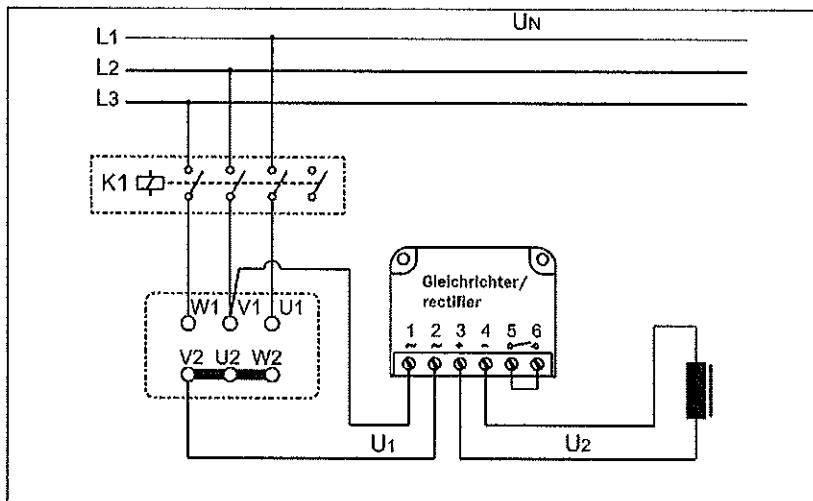

STROMVERSORGUNG

Die Gleichstrom-Bremsspule wird normalerweise über einen im Motor-Klemmkasten eingebauten Einweggleichrichter gespeist und ist für Spulenspannung 162-236 VDC, 85-133 VDC oder 24 VDC ohne Mehrpreis lieferbar (24V mit Blockklemme für externe Stromversorgung!). Entsprechende Gleichrichter- und Spulenspannungen sind gegen Mehrpreis für alle Sonderspannungen lieferbar. Zum Schutz gegen Überspannungen sind die Gleichrichter mit Varistoren beschaltet. Maximale Umgebungstemperatur +80°C. Bei Schalthäufigkeit über 1/s wegen Gleichrichter-Belastung rückfragen!

Einweggleichrichter (Normalausführung):

Der Anschluß des Bremssystems erfolgt über einen im Klemmenkasten eingebauten Gleichrichter entsprechend dem jeweils beigefügten Schaltbild.

Anschluß: Wechsellspannung 100% z.B. 400 V~
 Gleichspannung 45% z.B. 180 V=

POWER SUPPLY

The DC brake coil is normally supplied with power from a half wave rectifier installed in the motor terminal box which is available for 162-236 VDC, 85-133 VDC or 24 VDC coil voltage at no extra charge (24V with block terminal for external power supply). Rectifiers and coils are available for all special voltages at extra cost. The rectifiers are equipped with varistors to protect them against overvoltage. Max. ambient temperature for rectifiers is +80°C. For starting frequency above 1/s, contact us for rectifier loading capacity!

Half-wave rectifier (standard version):

The braking system is connected with a rectifier installed in the terminal box in accordance with the enclosed circuit diagram.

Connection: a. c. voltage 100% e.g. 400 V a.c.
 d. c. voltage 45% z.B. 180 V d.c.

STOP Achtung! Bei Betrieb eines Bremsmotors mit Frequenzumrichter ist die Bremsspule an eine externe Spannungsversorgung anzuschließen.
STOP Warning! If a brake motor is operated with a frequency converter, connect the brake coil to an external power supply.

12. Montage und Demontage von Schrumpfscheiben

12. Installation and removal of shrink disks

Montage:

Die Schrumpfscheiben werden einbaufertig geliefert. Sie sollten daher vor dem erstmaligen Verspannen nicht zerlegt werden.

Installation:

The shrink disks are supplied pre-assembled. Do not therefore dismantle them before tightening for the first time.

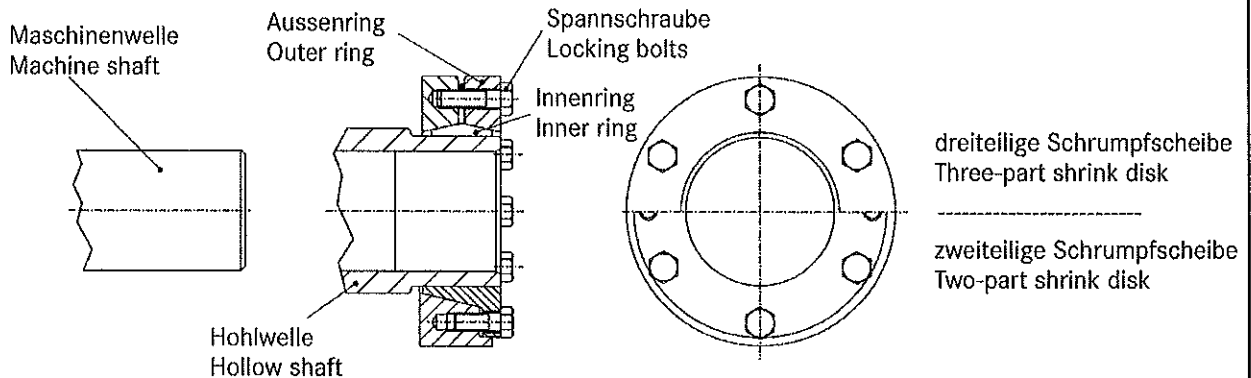

Montageschritte:

1. Entfetten der Nabenbohrung und der Maschinenwelle.
2. Aufschieben der Schrumpfscheibe auf die Hohlwelle. Im Bereich des Schrumpfscheiben-Sitzes kann die Außenfläche der Hohlwelle gefettet werden.

Installation procedure:

1. Degrease the hub bore and the machine shaft.
2. Slip the shrink disk onto the hollow shaft. The outer surface of the hollow shaft may be greased in the area of the shrink disk seat.

STOP ACHTUNG: SPANNSCHRAUBEN NICHT ANZIEHEN BEVOR DIE WELLE EINGEBAUT IST!

STOP WARNING: NEVER TIGHTEN THE LOCKING BOLTS BEFORE SHAFT INSTALLATION

3. Aufschieben der Hohlwelle auf die Maschinenwelle.
4. Anziehen aller Spannschrauben gleichmäßig und der Reihe nach (siehe Abbildung).

3. Push the hollow shaft onto the machine shaft.
4. Tighten all the locking bolts uniformly and in the right sequence (see figure).

Es sind mehrere Umläufe nötig, bis alle Schrauben das erforderliche Anzugsmoment aufweisen. Das Anzugsmoment muß mit einem Drehmomentschlüssel geprüft werden.

Tighten all the bolts successively several times until they display the required tightening torque. Check with a torque wrench.

STOP ACHTUNG: SCHRAUBEN NICHT "ÜBER KREUZ" ANZIEHEN!

STOP IMPORTANT: DO NOT TIGHTEN THE BOLTS IN DIAGONALLY OPPOSITE SEQUENCE!

Die Spannschraubenanzahl hängt von der Schrumpfscheibenbaugröße ab!

The number of locking bolts depends on the size of the shrink disks!

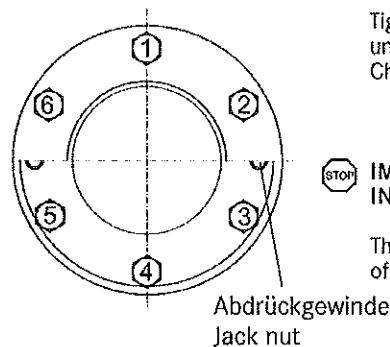

Demontage:

Removal:

Der Lösevorgang ist ähnlich dem des Verspannens.

The procedure is similar to installation, but in reverse order.

Demontageschritte:

Removal procedure:

1. Lösen der Spannschrauben, gleichmäßig und der Reihe nach. Jede Spannschraube darf anfangs pro Umlauf nur etwa eine Viertel-Umdrehung gelöst werden. Die Spannschrauben nie ganz herausdrehen.
2. Abdrücken des Innenringes mit Hilfe der Abdrückgewinde. Rostansatz, der sich auf der Maschinenwelle vor der Hohlwelle gebildet haben könnte, muß zuvor entfernt werden.
3. Ausbau der Maschinenwelle bzw. Abziehen der Hohlwelle von der Maschinenwelle.

1. Undo the locking bolts uniformly and in sequence. Only undo each locking bolt about a quarter turn initially. Do not remove the locking bolts completely.
2. Press the inner ring off using the jack nut. Remove any rust beforehand that may have formed on the machine shaft in front of the hollow shaft.
3. Remove the machine shaft and then slip the hollow shaft off the machine shaft.

Schritt 2 nur bei zweiteiliger Schrumpfscheibenausführung!

Step 2 only required for two-part shrink disk!

EUROPEStammhaus
Headquarter**AUSTRIA****WATT DRIVE ANTRIEBSTECHNIK GMBH**
Wöllersdorferstraße 68
A-2753 Markt Piesting
Tel.: +43 / 2633 / 404-0
Fax: +43 / 2633 / 404-220
e-mail: watt@wattdrive.com
Web: www.wattdrive.com**Belgium**S.A. Vermeire-Belting N.V.
Rue de la Filature 41
B-4800 Ensival-Verviers
Tel.: +32 / 87 / 32 23 60
Fax: +32 / 87 / 31 50 71
e-mail: vermeire.belting@vermeire.com
Web: www.vermeire.com**Denmark**Regal A/S
Industrivej 4
DK- 4000 Roskilde
Tel.: +45 / 46 77 70 00
Fax: +45 / 46 75 76 20
e-mail: regal@regal.dk
Web: www.regal.dk**Finland**LÖNNE SCANDINAVIA OY
Hernepellontie 11
FIN-00560 Helsinki
Tel.: +358 / 9 / 3424 300
Fax: +358 / 9 / 34243099
e-mail: info.finland@lonne.com
Web: www.lonne.com**France**Serax Transmissions
147 Rue Gambetta
59559 Comines Cedex
Tel.: +33 / (0)320145810
Fax: +33 / (0)320395148
e-mail: contact@serax.fr**Germany**WATT Drive Nord GmbH
Eickelstraße 4
D-59759 Arnsberg
Tel.: +49 / 2932 / 96 81 -0
Fax: +49 / 2932 / 96 81-81
e-mail: wdn@wattdrive.com**Germany**WATT Drive Nord GmbH
Vertriebs- und Servicecenter Köln
Friedrich Ebert Straße
D-51429 Bergisch Gladbach
Tel.: +49 / 2204 / 84 -2800
Fax: +49 / 2204 / 84 -2819
e-mail: wdn-koeln@wattdrive.com**Germany**WATT Drive Süd GmbH
Walkenmühlweg 49
D-72379 Hechingen
Tel.: +49 / 7471 / 9865-0
Fax: +49 / 7471 / 9865-29
e-mail: wds@wattdrive.com**Germany**WATT DRIVE Vertriebs- und Servicecenter
Max Lamb GmbH & Co KG,
Am Bauhof
D-97076 Würzburg
Tel.: +49 / 931 / 27 94-0
Fax: +49 / 931 / 27 45 57
e-mail: ant@lamb.de**Greece**Control Technik S.A.
22 Vas. Georgiou B' Str.
Athens 116 35
Tel.: +30 / 1 / 7232 655
Fax: +30 / 1 / 7214 683
e-mail: contech@hol.gr
Web: www.controltechnik.gr**Netherlands**Euronorm Aandrijftechniek
Zweedsestraat 1
NL - 7202 CK Zutphen
Tel.: +31 / 575 599 700
Fax: +31 / 575 599 701
e-mail: sales@euronorm.nl
Web: www.euronorm.nl**Norway**LONNE SCANDINAVIA AS
Postb. 160 Nyborg
N-5871 Bergen
Tel.: +47 / 55 39 10 00
Fax: +47 / 55 39 11 00
e-mail: info.norway@lonne.com
Web: www.lonne.com**Slovakia**Watt Drive Slovensko
D.I. Daniel Svolik
P.V.Rovnianka 8/87
SK-03601 Martin
Tel.: +421 / 842 / 4276 668
Mobil: +421 / 905 / 438 499
Fax: +421 / 842 / 4276 668**Slovenia**SB-Elektronika
Branko Skribe s.p.
Ljubljanska 100
SLO-2000 Maribor
Tel.: +386 / 2 / 42 96 370
Mobil: +386 / 41 / 674 828
Fax: +386 / 2 / 42 96 371
e-mail: sb.elektronika@siol.net**Spain**Atcor / Geryma S.A.
Carretera del Medio 141
E-08907 L'Hospitalet de Llobregat
Tel.: +34 / 93 335 91 53
Fax: +34 / 93 335 20 89
e-mail: atcorgerymasa@retemail.es**Sweden**Bevl EL AB
Box 41
SE - 38421 Blomstermala
Tel.: +46 / 499 / 27100
Fax: +46 / 499 / 20008
e-mail: sales@bev1.se
Web: www.bev1.com**Switzerland**Elektromotorenwerk Brienz AG
Mattenweg 1
CH - 3855 Brienz
Tel.: +41 / 33 / 951 31 31
Fax: +41 / 33 / 951 34 55
e-mail: info@emwb.ch
Web: www.emwb.ch

AMERICA**U.S.A.-
Midwest**

DieQua Corporation
180 Covington Drive
Bloomington / Chicago
Illinois USA 60108-3105
Tel.: +1 / 630 / 980 1133
Fax: +1 / 630 / 980 1232
e-mail: info@diequa.com
Web: www.diequa.com

RUSSIA**Russia**

IBC Industrial Business Consulting
13, Groholsky per., building 2
RU 129090 Moscow
Tel.: +7 / 095 / 974 1223
Fax: +7 / 095 / 974 1224
e-mail: ibc@online.ru

AFRICA AND ASIA**Egypt**

Original Group
for Trading & Marketing
Commercial Agents - Imp. & Exp.
2 Road 79, P.O.Box 783
11728 Maadi
Tel.: +202 / 75 09 031/2
Fax: +202 / 75 09 034
e-mail: orggoup@starnet.com.eg

**China
Hong Kong**

RITECH AUTOMATION & EQUIPMENT LIMITED
Flat 7, 11/F, South China Industrial Building
No. 1 Chun Pin Street, Kwai Chung
New Territories, Hong Kong
Tel.: +852 / 2410 1819
Fax: +852 / 2410 1735
e-mail: ritech@ctimail.com

Indonesia

PT. LEMBAYUNG
Gedung Graha Eka Citta
Jalan Budi Raya No. 9, Kemanggisan
Jakarta 11530
Tel.: +62 / 21 / 54 90 641, 53 28 140, 53 28 141,
53 67 02 48
Fax: +62 / 21 / 53 05 593, 83 08 550
e-mail: lembayun@cbn.net.id

Korea

WATT DRIVE CO., Ltd / Korea
Ji-won B/D # B-306,
Shiheung Yoo Tong Center,
984, Shiheung 3-dong, Keum-Chon Gu,
Seoul, 153-755
Tel.: +82 / 2 / 894 1230
Fax +82 / 2 / 894 1243
e-mail: wdk@wattdrive.co.kr
Web: www.wattdrive.co.kr

Malaysia

WATT Euro-Drive (Malaysia) Sdn Bhd
No. 17 Jalan Bulan U5/8
Bandar Pinggiran Subang 2
40150 Shah Alam
Selangor Darul Ehsan
Tel.: +603 / 785 91626, 785 91613
Fax: +603 / 785 91623
email: watt-kl@tm.net.my
Web: www.wattdrive.com.my

Philippines

AVESCO Marketing Corporation
Aurora Blvd., cor. Yale Street
Cubao, Quezon City
Tel.: +63 / 2 / 912 8881
Fax: +63 / 2 / 912 2999, 912 2911, 912 2352
e-mail: avesco@pacific.net.ph

Singapore

WATT Euro-Drive (Far East) Pte Ltd
67B, Joo Koon Circle
Singapore 629082
Tel.: +65 / 686 22 220
Fax: +65 / 686 23 330
e-mail: watteuro@pacific.net.sg

Taiwan

WOWTECH International Co., Ltd.
10F, No. 18, Chinsan South Road, Sec.2
Taipei
Tel.: +886 / 2 / 2 393 16 94
Fax: +886 / 2 / 2 393 16 72
e-mail: wowtech@ms12.hinet.net

Thailand

Far East International Co., Ltd.
4/9 Moo 16 Theaparok road,
Bangsaothong Bangsaothong
Samutprakarn 10540
Tel.: +662 / 705 0623/7
Tel.: +662 / 315 1331
Fax: +662 / 315 1673
e-mail: fareast@bkk.a-net.net.th

Thailand

AMCO Advanced Mechanics Co., Ltd.
27/1 Soi Areesumphon 5 Phayathai
Bangkok 10400
Tel.: +66 / 2 / 617 10 26-30
Fax: +66 / 2 / 271 28 71
e-mail: info@advancedmech.com
Web: www.advancedmech.com

Vietnam

Hoang Quoc Co., Ltd.
509 Kim Ma Street
Hanoi
Tel.: +84 / 4 / 831 7421
Fax: +84 / 4 / 831 7433
e-mail: hoangquoc@hn.vnn.vn

Vietnam

Thien Nghi Trading & Services Co., Ltd
210 Nguyen Thai Binh Street,
Ward 12, Tan Binh District
Ho Chi Minh City, Vietnam
Tel: +84 / 8 / 811 5476
Fax: +84 / 8 / 811 5475



**WATT Drives
the World**

WATT DRIVE ANTRIEBSTECHNIK GMBH

A-2753 Markt Piesting

Wöllersdorferstraße 68

Austria, EUROPE

Tel.: +43 / 2633 / 404-0

Fax: +43 / 2633 / 404-220

e-mail: watt@wattdrive.com

Web: www.wattdrive.com

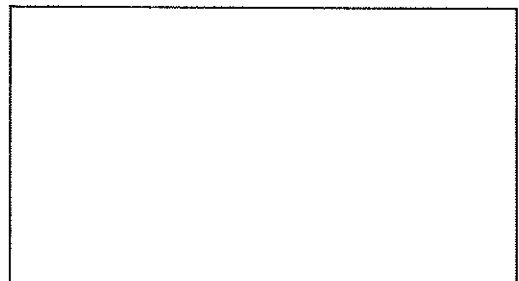

**watt
drive** 

APPENDIX C

GEARBOX Model:RHX-155-600

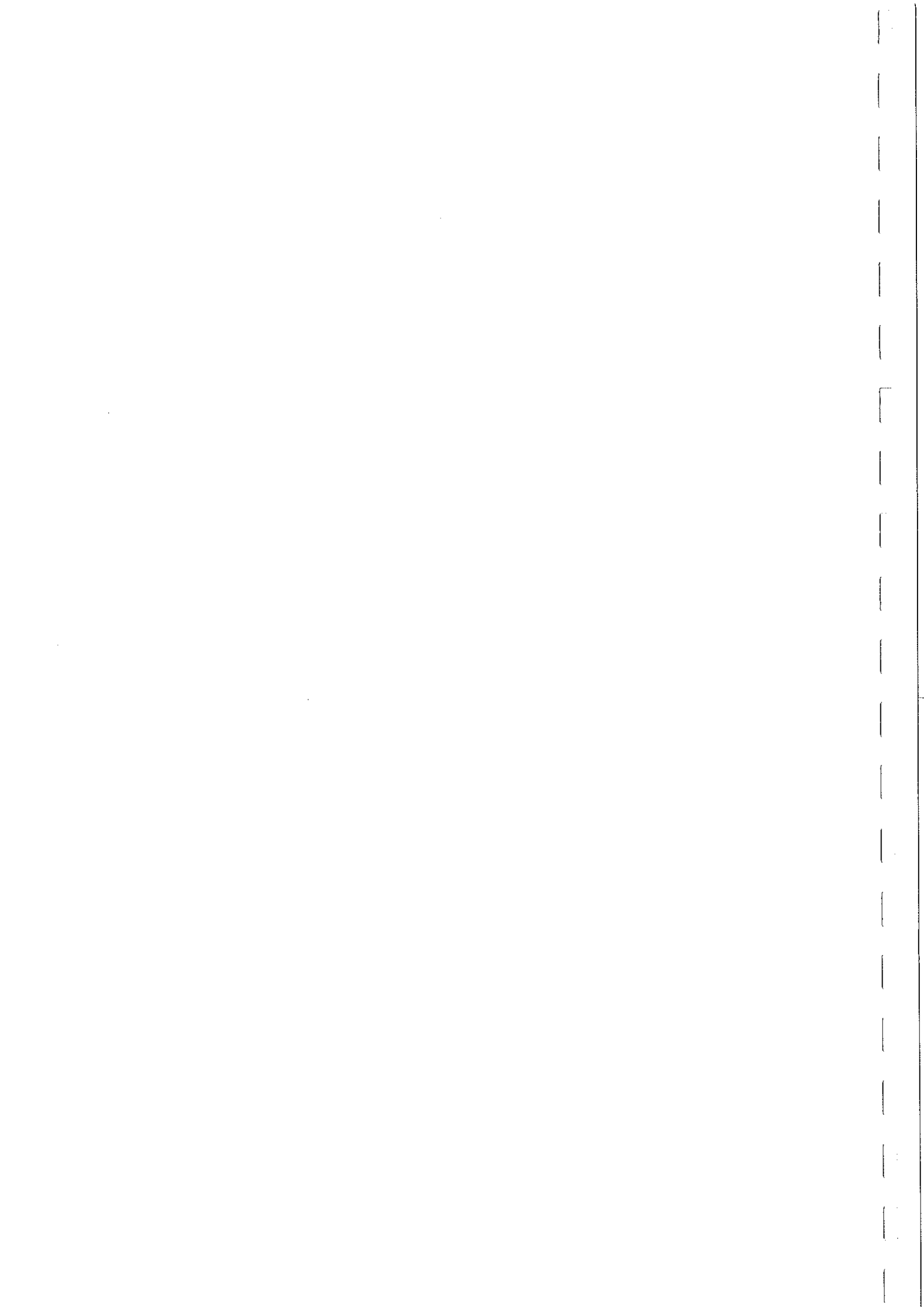

ITEM	QTY	DESCRIPTION
1	1	2nd Case
2	1	1st Case
3	1	Input Shaft Flange
4	1	Output Shaft Cover
5	1	1st Case Cover
6	1	Shaft End Cover
7	1	Shaft End Cover
8	1	Output Shaft
9	1	Worm Shaft
10	1	Input Shaft
11	1	Worm Wheel
12	12	Worm Wheel
13	6	Hex. Head Bolt M16
14	4	Cap Bolt M12
15	4	Hex. Head Bolt M12
16	4	Cap Bolt M12
17	8	Cap Bolt M12
18	1	Cap Bolt M12
19	1	Output Shaft Key
20	1	Output Shaft Key
21	1	Retaining Ring
22	2	Taper Roller Bearing
23	1	Taper Roller Bearing
24	1	Taper Roller Bearing
25	2	Ball Bearing
26	2	Oil Seal
27	1	Oil Seal
28	1	Oil Seal
29	2	Oil Plug 1/4"
30	1	Oil Plug 1/2"
31	1	Air Plug 1/2"
32	1	Oil Plug 1/4"
33	1	Worm Wheel Key
34	1	Oil Level Gage
35	1	Eye Bolt

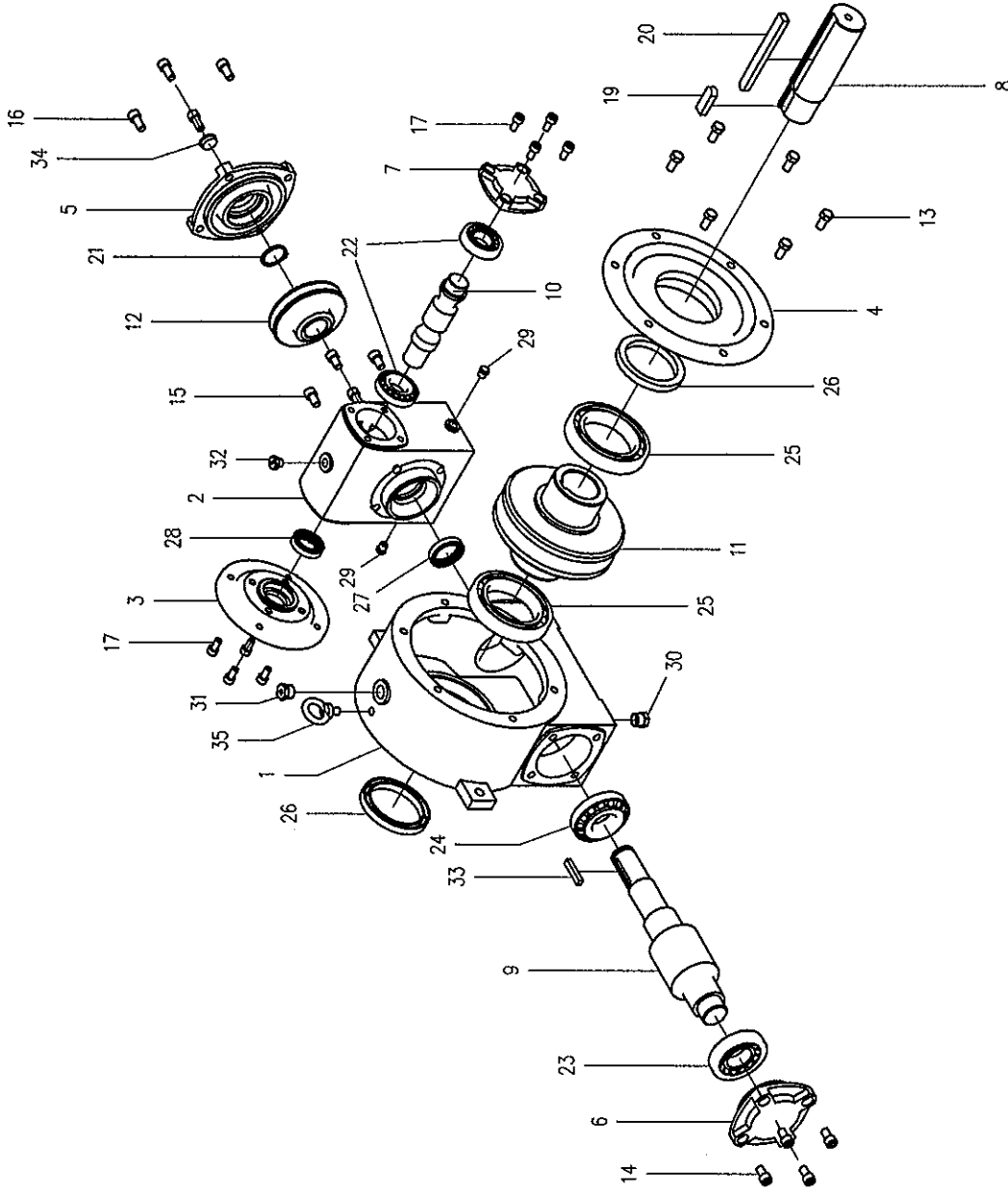

 ROMAR POSITIONING EQUIPMENT PTE LTD http://www.romar.com.sg		PROJECT/MODEL : GEARBOX RHX-155-600-2-E-IEC	
DRAWN NAME SPAN	DATE 28-04-04	CLIENT : -	SCALE N.T.S.
APPROVED		DWG. NAME : GENERAL ASSEMBLY	REVISION: 0
		DWG. NO. : RHX-155-600-2-E-IEC	SHEET NO.: 1 OF 1

ALL DIMENSIONS IN MM, UNLESS OTHERWISE SPECIFIED.

SIZE: A4

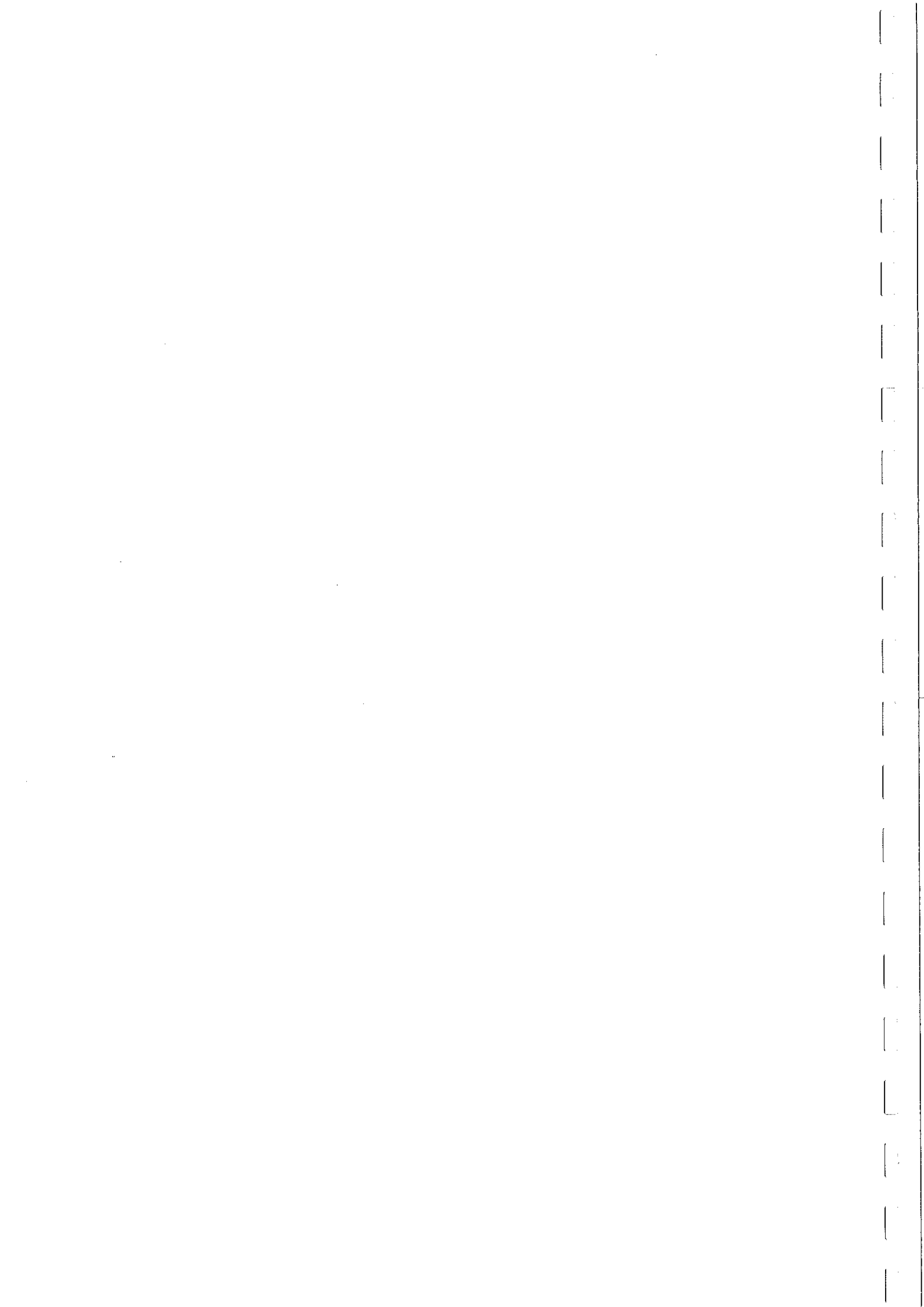

ITEM	QTY	DESCRIPTION
1	1	2nd Case
2	1	1st Case
3	1	Input Shaft Flange
4	1	Output Shaft Cover
5	1	1st Case Cover
6	1	Shaft End Cover
7	1	Shaft End Cover
8	1	Output Shaft
9	1	Worm Shaft
10	1	Input Shaft
11	1	Worm Wheel
12	12	Worm Wheel
13	6	Hex. Head Bolt M16
14	4	Cap Bolt M12
15	4	Hex. Head Bolt M12
16	4	Cap Bolt M12
17	8	Cap Bolt M12
18	1	Cap Bolt M12
19	1	Output Shaft Key
20	1	Output Shaft Key
21	1	Retaining Ring
22	2	Taper Roller Bearing
23	1	Taper Roller Bearing
24	1	Taper Roller Bearing
25	2	Ball Bearing
26	2	Oil Seal
27	1	Oil Seal
28	1	Oil Seal
29	2	Oil Plug 1/4"
30	1	Oil Plug 1/2"
31	1	Air Plug 1/2"
32	1	Oil Plug 1/4"
33	1	Worm Wheel Key
34	1	Oil Level Gage
35	1	Eye Bolt

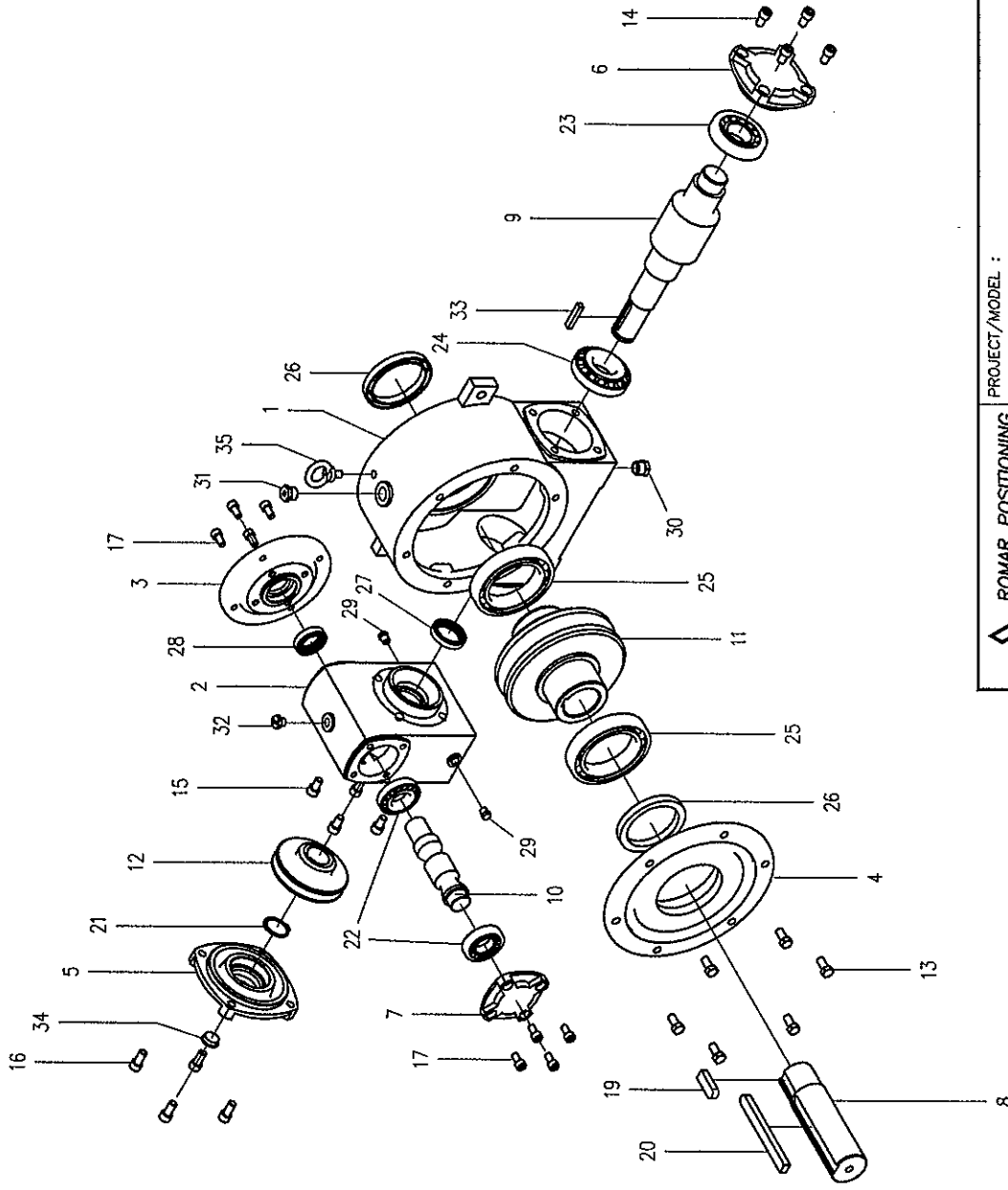

 ROMAR POSITIONING EQUIPMENT PTE LTD http://www.romar.com.sg		PROJECT/MODEL : GEARBOX RHX-155-600-2-F-IEC	
CLIENT : -	SCALE : N.T.S.	REVISION : 0	SHEET NO. : 1 OF 1
DRAWN : SFAN	DATE : 28-04-04	DWG. NAME : GENERAL ASSEMBLY	
APPROVED :	DWG. NO. : RHX-155-600-2-F-IEC		

ALL DIMENSIONS IN MM, UNLESS OTHERWISE SPECIFIED.

SIZE: A4

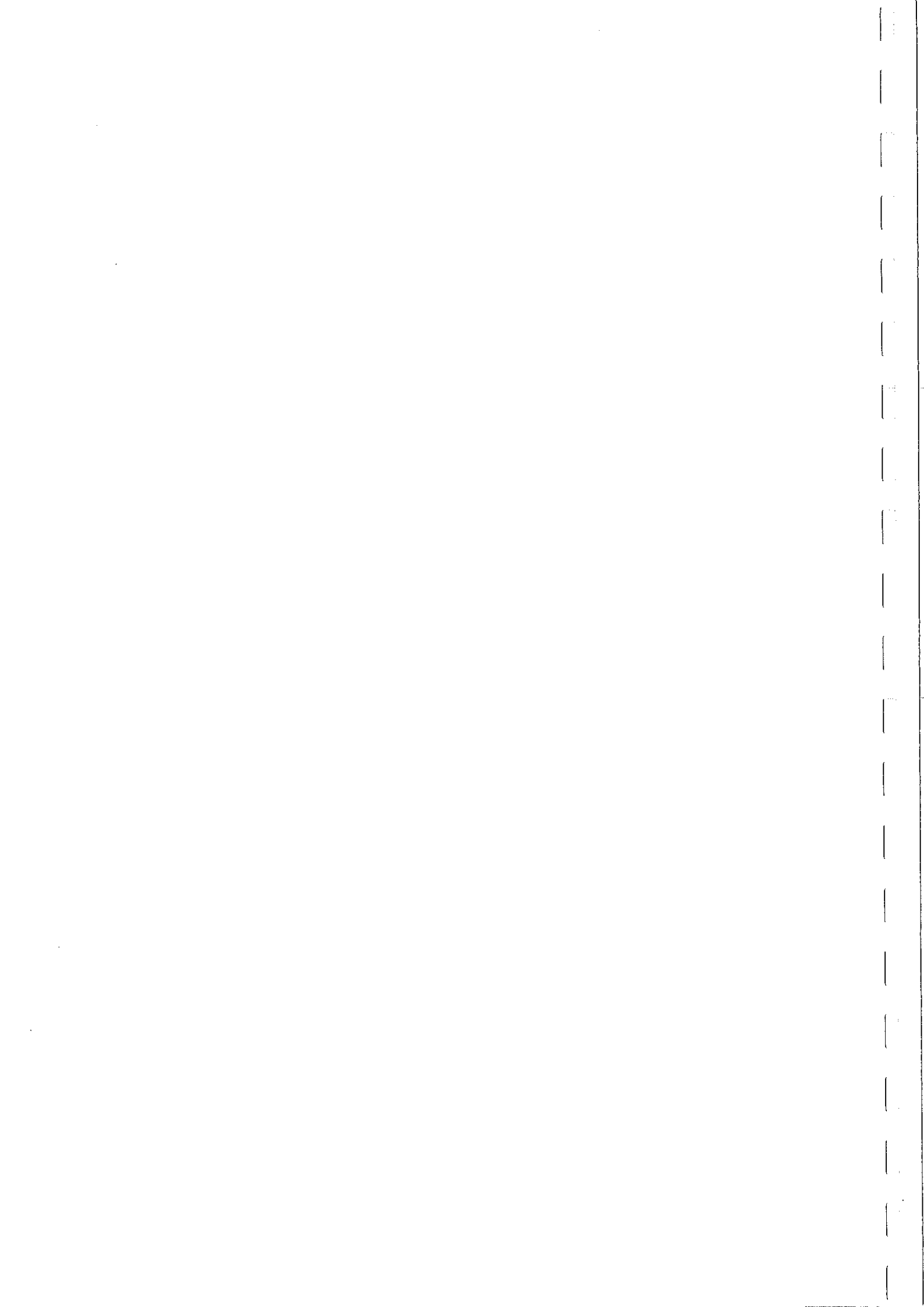

APPENDIX D

**GUIDELINE FOR VESSEL
DIAMETER**

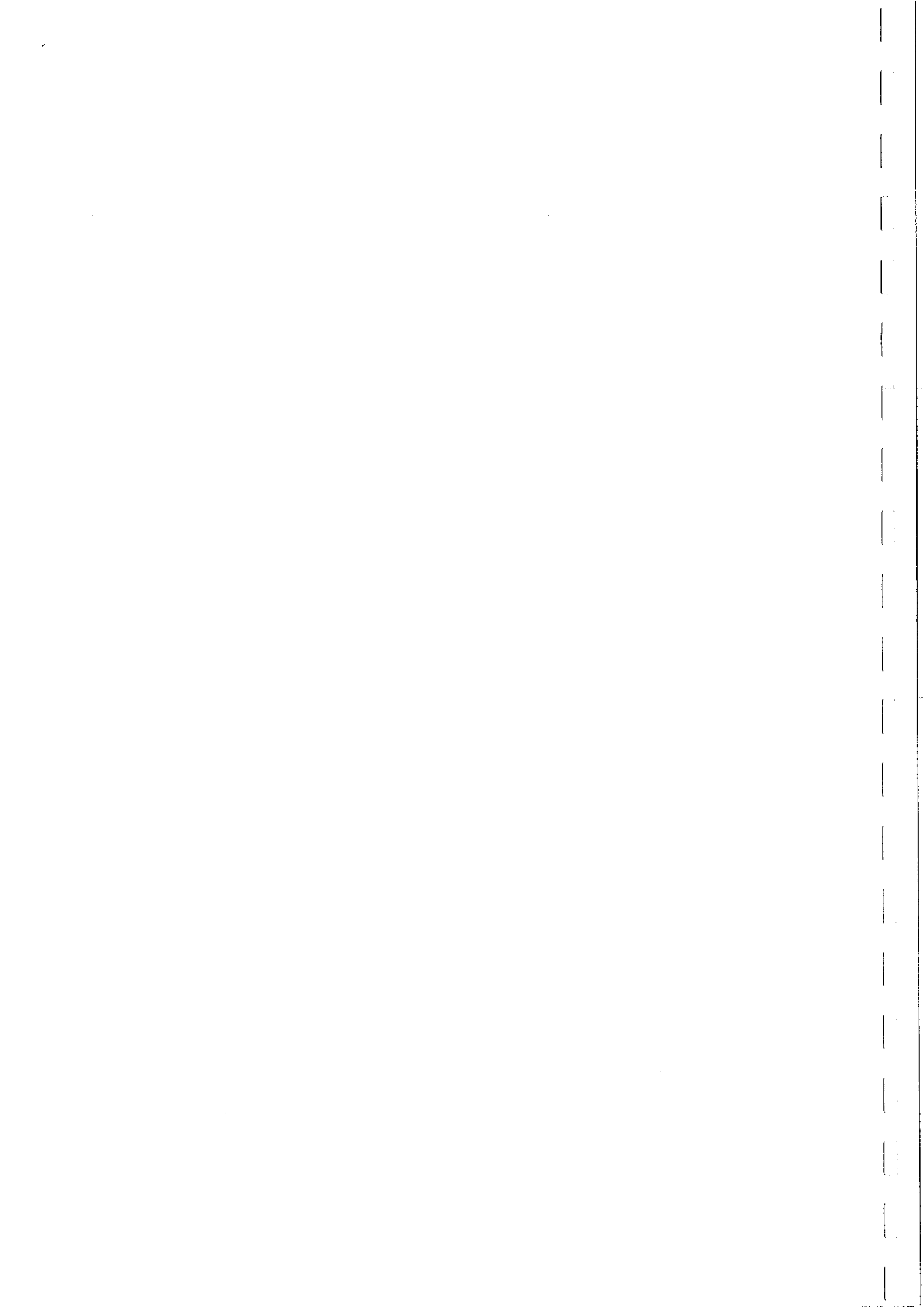

Rotator Selection Chart - Standard 30 to 120 MT

Ref: SD-RXXX-T002 Rev: 0



Guidelines for Vessel Diameter in mm (D)

CC (mm)	Included Angle, θ (in deg)												
	30	35	40	45	50	55	60	65	70	75	80	85	90
700	2184	1807	1526	1308	1136	995	879	782	700	629	568	515	469
1100	3729	3137	2695	2354	2082	1862	1679	1527	1397	1286	1191	1108	1035
1500	5275	4468	3865	3399	3029	2728	2479	2271	2094	1943	1813	1700	1601
1900	6820	5798	5035	4444	3975	3594	3279	3016	2792	2600	2435	2292	2166
2300	8366	7128	6204	5489	4922	4460	4079	3760	3489	3257	3057	2884	2732
2700	9911	8458	7374	6535	5868	5327	4879	4504	4187	3915	3680	3476	3292
3100	11457	9788	8543	7580	6815	6193	5679	5249	4887	4572	4257	3996	3749

Vessel Clearance from Skid in mm (C)

CC (mm)	Included Angle, θ (in deg)												
	30	35	40	45	50	55	60	65	70	75	80	85	90
700	519	511	503	495	487	479	471	463	455	446	438	429	420
1100	493	480	468	456	443	430	418	405	392	378	365	351	337
1500	466	450	433	416	399	381	364	346	329	310	292	273	254
1900	440	419	397	376	354	333	310	288	265	243	219	196	171
2300	414	388	362	336	310	284	257	230	202	175	146	118	89
2700	387	357	327	296	266	235	203	172	139	107	74	40	11
3100	361	326	292	257	221	186	150	113	76	39	1	0	0

Overall Vessel Height in mm (H)

CC (mm)	Included Angle, θ (in deg)												
	30	35	40	45	50	55	60	65	70	75	80	85	90
700	2903	2518	2229	2004	1823	1675	1551	1445	1354	1275	1206	1144	1089
1100	4422	3818	3364	3009	2725	2492	2297	2131	1989	1865	1755	1659	1572
1500	5941	5117	4498	4015	3627	3309	3043	2817	2623	2454	2305	2173	2055
1900	7460	6417	5632	5020	4529	4127	3790	3504	3257	3043	2854	2687	2538
2300	8979	7716	6766	6026	5432	4944	4536	4190	3892	3632	3404	3202	3024
2700	10499	9015	7901	7031	6334	5761	5283	4876	4526	4221	3953	3716	3501
3100	12018	10315	9035	8037	7236	6579	6029	5562	5160	4810	4496	4216	3966

- Note:
1. This chart is applicable to ROMAR ROTATOR using diameter 20-1/2" tires.
 2. Recommended Included Angle should be greater the 45 degree unless vessel is true concentric.
 3. Shaded portion is not recommended.

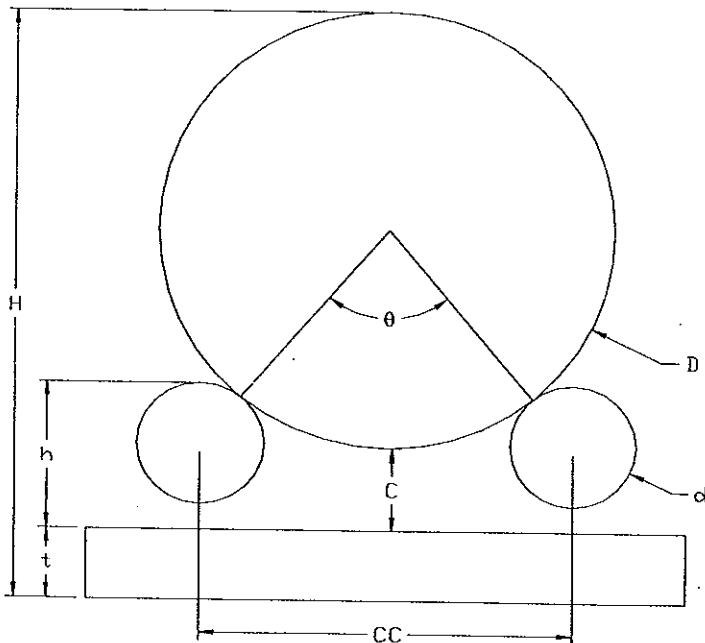

Roller Dia. (d) = 520.7 mm
 Roller Ht. from Skid (h) = 565 mm
 Skid Ht. (t) = 200 mm

Controlled To
 Shawn For JW 18/3