

MV4545

Traveling Base

The **Harbach Positioning** Heavy Duty series of Column & Boom Manipulators are specifically designed and built to withstand the harsh and rugged environments expected in the welding industry. It includes the following features:

- A slewing ring for column mounting, thereby providing a smooth 360° lockable rotation.
- All vertical and horizontal rails are precisely machined in single runs giving unsurpassed smooth and steady travel.
- Latest Inverter drives fitted for variable speed of horizontal boom arm travel and rail travel car (optional).
- Worm gearbox for vertical travel via AC motor complete with brake for added safety.
- High tensile roller chain used for vertical travel with the addition of a counter balance system provides smooth effortless vertical travel.
- IP 55 control box and low voltage pendant control station.
- Standard safety feature includes anti-fall device and limit switches for all functions.
- Internally trunked cabling.

Inclusive:

- Power source mounting bracket of your choice

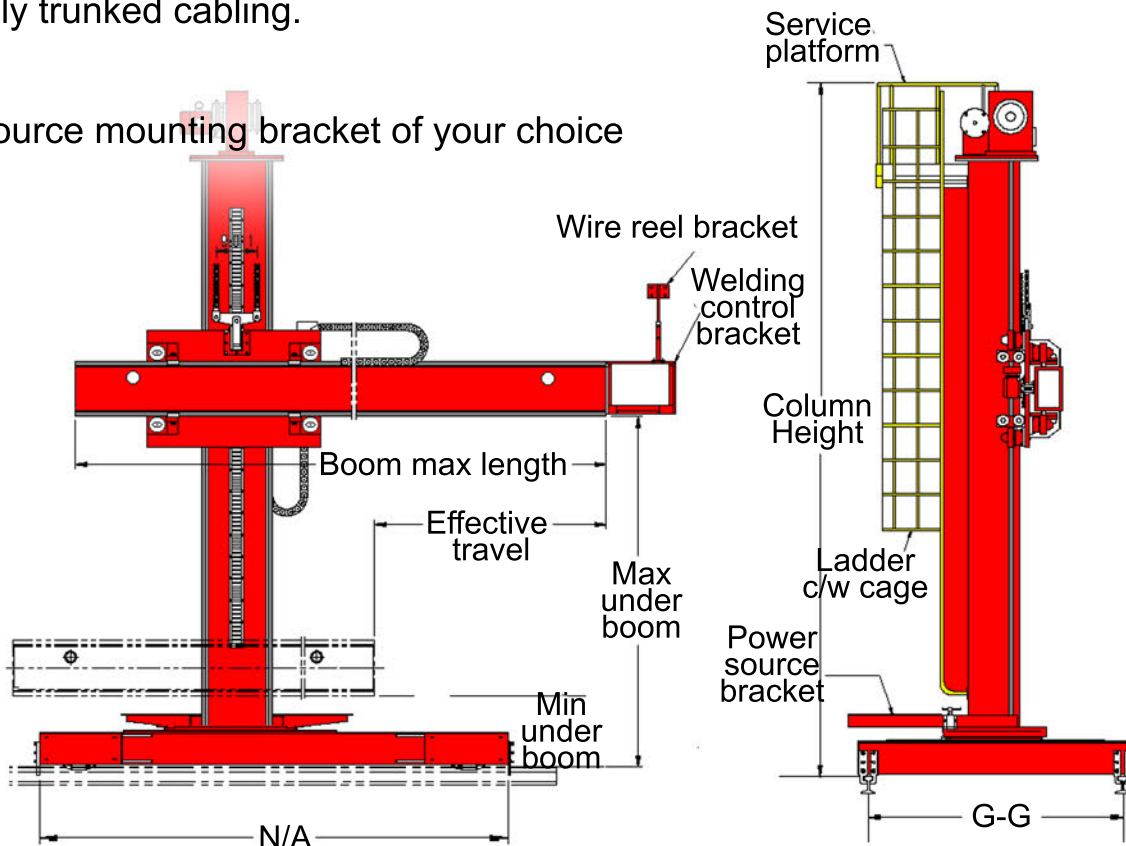

Heavy Duty Column & Boom Manipulator Series

MV4545

Optional Features Include

- Travel car, manual or motorized variable speed operated via the same pendant station via selector switch.
- X-Y slide, manual or motorized, operated via the same pendant station.
- Compressed air operated flux recovery unit
- Welding power source & wire feeder controller system

All **Harbach Positioning** Column & Boom Manipulators are grit blasted to SA2.5 and two coats of zinc phosphate paint followed by one coat of polyurethane paint work will ensure that your investment provides you with many years of uninterrupted service.

MV series with Traveling Base

DIMENSION SPECIFICATIONS

Model with Travelcar	4040-TCM	4545-TCM	5050-TCM	5555-TCM	6060-TCM	6565-TCM
Column height	5684	6184	6684	7184	7684	8184
Boom length	6500	7000	7500	8000	8500	9000
Vertical under boom (max)	4000	4500	5000	5500	6000	6500
Boom effective range	4000	4500	5000	5500	6000	6500

Model with Travelcar	7070-TCM	7575-TCM
Column height	8684	9184
Boom length	9500	10000
Vertical under boom (max)	7000	7500
Boom effective range	7000	7500

Heavy Duty Column & Boom Manipulator Series

MV4545

DATA SPECIFICATIONS

Vertical Speed	1250mm/min
Boom Speed	150~1500mm/min
Travel Speed	200~2500mm/min
Vertical Drive	AC 2.2kw c/w brake
Boom Drive	AC 0.75kw c/w force cooling
Travel Car Drive	AC 0.75kw c/w brake
Electrical Panel	IP55 class
Base Type	Motorized travel car
Travel car G-G Rail	Factory advice
Slewing	Manual
Power Supply	3-phase line
Control Voltage	24Vac
Control Means	Push button pendant c/w m cable
Surface Preparation	Gritblast to SA2.5
Painting	2 coats zinc phosphate, 1 coat polyurethane
Color	Red

Note: Scope of cutting table, rail base support and civil works (By Others)

OPTIONS

X-Y Slides 200mm slide	■
Slewing Drive	■
Welding Control	■
Welding Power Source	■
Flux Recovery	■
Walk way	■
Cat Ladder	■

▲ Specify requirement

■ Optional

★ Standard

◆ Specify quantity

MV4545

Manipulator Rail Gauge Table

MV series

Boom Height	4	4.5	5	5.5	6	6.5	7	7.5	8
4	GG2000		GG2500			GG3000		GG3000 c/w counterweight	
4.5									
5	GG2000		GG2500			GG3000		GG3000 c/w counterweight	
5.5									
6	GG2000		GG2500			GG3000		GG3000 c/w counterweight	
6.5									
7	GG2000		GG2500			GG3000		GG3000 c/w counterweight	
7.5									
8	GG2000		GG2500			GG3000		GG3000 c/w counterweight	

Notes:

V denotes Max.Under Boom Height (Vertical), in hundreds of mm. i.e. 20 = 2000mm

H denotes Effective Boom Travel (Horizontal), in hundreds of mm. i.e. 20 = 2000mm

CW denotes with Counterweight

Heavy Duty Column & Boom Manipulator Series

MV4545

MV series with Fixed Base

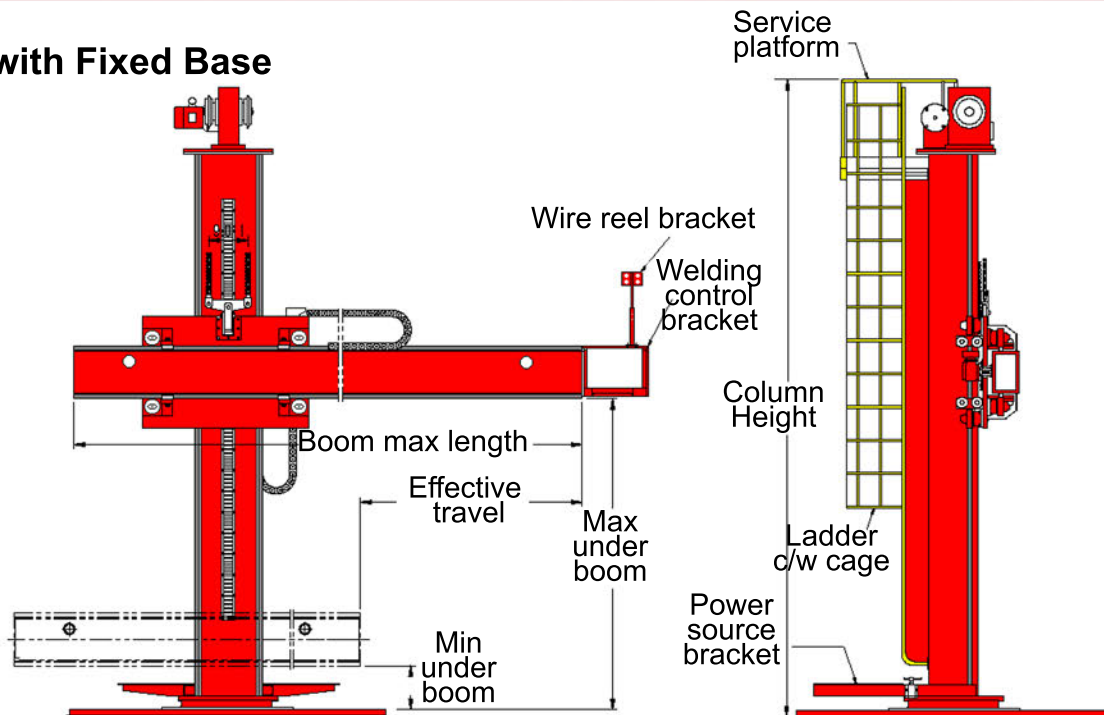

DIMENSION SPECIFICATIONS

Model with fixed base	4040	4545	5050	5555	6060	6565
Column height	5684	6184	6684	7184	7684	8184
Boom henght	6500	7000	7500	8000	8500	9000
Vertical under boom (max)	4000	4500	5000	5500	6000	6500
Boom effective range	4000	4500	5000	5500	6000	6500

Model with TCM	7070	7575
Column height	8684	9184
Boom length	9500	10000
Vertical under boom (max)	7000	7500
Boom effective range	7000	7500

Heavy Duty Column & Boom Manipulator Series

MV4545

DATA SPECIFICATIONS

Vertical Speed	1250mm/min
Boom Speed	150~1500mm/min
Travel Speed	200~2500mm/min
Vertical Drive	AC 2.2kw c/w brake
Boom Drive	AC 0.75kw c/w force cooling
Electrical Panel	IP55 class
Base Type	Motorized travel car
Slewing	Manual
Power Supply	3-phase line
Control Voltage	24Vac
Control Means	Push button pendant c/w m cable
Surface Preparation	Gritblast to SA2.5
Painting	2 coats zinc phosphate, 1 coat polyurethane
Color	RAL5015 blue

Note: Scope of cutting table, rail base support and civil works (By Others)

OPTIONS

X-Y Slides 200mm slide	■
Slewing Drive	■
Welding Control	■
Welding Power Source	■
Flux Recovery	■
Walk way	■
Cat Ladder	■

▲ Specify requirement

■ Optional

★ Standard

◆ Specify quantity

Heavy Duty Column & Boom Manipulator Series

Specifications for Manipulator

1	Model	MV4545-PT2000-WE
2	Max. Under Boom Height	4500mm
3	Effective Boom Travel	4500mm
4	Vertical Speed	1250mm/min running at 50Hz
5	Boom Speed	165~1650mm/min running at 5~50Hz
6	Travel Speed	333~3335mm/min running at 5~50Hz
7	Vertical Drive	3.0KW AC Motor c/w Brake
8	Boom Drive	0.55KW AC Motor c/w Force Cooling
9	Travel Car Drive	0.75KW AC Motor c/w Brake
10	Drive Control	Inverter (Toggle between Boom & Travel Car)
11	Welding Controller/Feeder	T.B.A. (by Others)
12	Welding Power Source/Brand	T.B.A. (by Others)
13	Electrical Panel	Yes
14	Base Type	Travel Car Motorized
15	Travel Car Rail G-G	2000mm
16	Slewing Feature	Manual, ±180°
17	Slewing Drive	N.A.
18	X-Y Slides	No
19	Operator Chair	No
20	Flux Recovery	No
21	Incoming Supply	380/400/415V-3P-50Hz or 440/460/480V-3P-60Hz ¹
22	Control Voltage	24Vac
23	Control Means	Via Push Button Pendant c/w 11m Cable
24	Payload	250kg
25	Surface Preparation	Gritblast to SA2.5
26	Painting	2 Coats Zinc Phosphate, 1 Coat Polyurethane
27	Colour	RAL3003 Red & RAL9005 Black for Travelcar only
28	Qty	1 Unit
29	Weight	~5700kg

Note:

1. Input terminals are wired for 400V by default.
2. This drawing is accurate at the time of preparation and maybe subject to final design change.

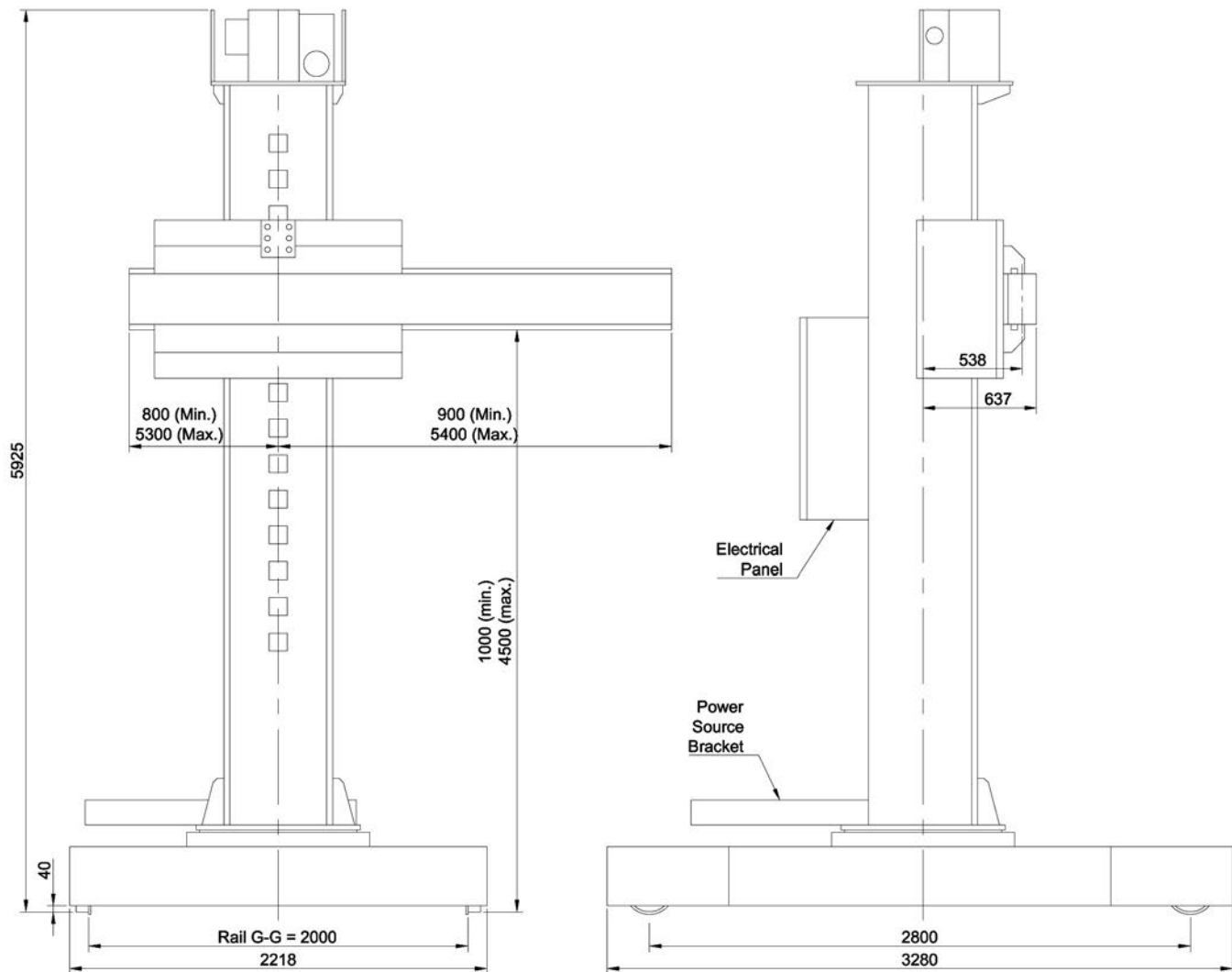

All dimensions in mm unless otherwise specified.

	CUSTOMER APPROVAL	CHECKED BY:	DRAWN BY: IC	REV	DATE	DESCRIPTION	EDIT BY	REMARKS	
				CUSTOMER:					
				DRAWING NAME:	Very Heavy Duty Manipulator				SCALE: N.T.S.
				DRAWING NO.:	MV4545-PT2000-WE				REVISION: 0
				<small>THE ORIGINAL AND ALL COPIES OF THIS DOCUMENT TOGETHER WITH THE COPYRIGHT THEREOF ARE THE SOLE PROPERTY OF HARBACH MARKETING, INC. DESIGN AND SPECIFICATIONS ARE SUBJECT TO CHANGE WITHOUT PRIOR NOTICE.</small>				SHEET: 1 OF 1	

23-03-2011